

GENERAL NOTES

- DESIGN IS BASED ON THE ASSUMPTION THAT BACKFILL WITHIN THE REINFORCED SOIL MASS, METHODS OF CONSTRUCTION AND THE QUALITY OF MATERIALS CONFORM TO THE THE REQUIREMENTS OF HILFIKER RETAINING WALLS.
 - ASSUMED MATERIAL CHARACTERISTICS:
 - WALL BACKFILL (CONTRACTOR TO VERIFY BY TEST):
 - TOTAL UNIT WEIGHT: 130 PCF
 - INTERNAL FRICTION ANGLE: 34° (ASTM D3080)
 - COHESION: 0 PSF
 - RETAINED BACKFILL:
 - TOTAL UNIT WEIGHT: 125 PCF
 - INTERNAL FRICTION ANGLE: 32°
 - COHESION: 0 PSF
 - FOUNDATION SOILS:
 - TOTAL UNIT WEIGHT: 120 PCF
 - INTERNAL FRICTION ANGLE: 28°
 - COHESION: 50 PSF
 - FACTORED BEARING CAPACITY RESISTANCE OF FOUNDATION:
 - q-ult-STATIC: 7,000 LB/FT²
 - q-ult-SEISMIC: 9,300 LB/FT²
- IF ACTUAL MATERIAL CHARACTERISTICS, GRADES OR DIMENSIONS OF SOIL MATERIALS DIFFER FROM THOSE LISTED ABOVE OR SHOWN ON THE PLANS, HILFIKER RETAINING WALLS SHALL BE NOTIFIED TO EVALUATE THE NEED TO REDESIGN.
- THE DESIGN REQUIRES A NON-SATURATED BACKFILL. SURFACE AND SUB-SURFACE DRAINAGE CONTROL MAY BE REQUIRED TO PREVENT SATURATION OF THE BACKFILL OR RELIEVE HYDROSTATIC PRESSURES.
 - SURFACE DRAINAGE CONTROL SHALL BE AS SPECIFIED IN THE PROJECT PLANS AND SPECIFICATIONS OR AS DIRECTED BY THE OWNER'S ENGINEER. PAYMENT FOR DRAINAGE SHALL BE AS SPECIFIED IN THE PROJECT SPECIFICATIONS.
 - SOIL REINFORCEMENTS SHALL BE FABRICATED OF WELDED WIRE FABRIC CONFORMING TO AASHTO M-32 AND M-55 AND SHALL BE GALVANIZED IN ACCORDANCE WITH AASHTO M-111 FOLLOWING FABRICATION.
 - THIS DESIGN SUBMITTAL IS BASED ON ASTM A1115 - STANDARD PRACTICE FOR CONSTRUCTION OF MECHANICALLY STABILIZED EARTH WALLS WITH INEXTENSIBLE SOIL REINFORCEMENT (LATEST APPROVAL).
 - THIS SUBMITTAL INCLUDES PERMANENT MSE WALLS . PERMANENT MSE WALLS ARE DESIGNED FOR 75 YEARS OF SERVICE. THE OWNER IS THE U.S. FOREST SERVICE.
 - SHANNON & WILSON IS NOT THE OWNER'S "ENGINEER OF RECORD" OR THE OWNER'S "GEOTECHNICAL ENGINEER" OR THE OWNER'S "HYDRAULIC ENGINEER," AS DESCRIBED IN ASTM A1115. THE OWNER IS RESPONSIBLE FOR THE FOLLOWING:
 - EVALUATING GLOBAL STABILITY
 - ESTABLISHING FOUNDATION BEARING RESISTANCE DESIGN CRITERIA
 - IMPLEMENTING AN ADEQUATE QUALITY CONTROL PROGRAM
 - HILFIKER RETAINING WALLS (800-762-8962) IS THE "WALL SUPPLIER" WHOSE SYSTEM AND COMPONENTS ARE THE SOLE BASIS OF THIS SUBMITTAL.
 - SHANNON & WILSON (208-658-8700) IS THE "WALL DESIGN ENGINEER," AS DESCRIBED IN ASTM A1115. SHANNON & WILSON HAS SPECIFIED THE TYPE(S), SIZES, AND LOCATIONS OF BURIED REINFORCEMENTS FOR THIS SUBMITTAL.
 - THE ENGINEER OF RECORD ADMINISTERS THE OWNER'S REQUIREMENTS FOR THE LONG-TERM STABILITY OF THE MSE WALL (MSEW), INCLUDING:
 - FOUNDATION PREPARATION REQUIREMENTS OF THE GEOTECHNICAL ENGINEER
 - SCOUR COUNTERMEASURES ALONG THE TOE
 - EROSION COUNTERMEASURES AT THE ENDS
 - SURFACE WATER DRAINAGE CONTROLS ABOVE THE WALL
 - CONSTRUCTION OF THE SUPPLIED MSEW SYSTEM WITH ALL OF ITS APPURTENANT COMPONENTS
 - PROTECTION OF REINFORCEMENT, SUCH THAT UNAUTHORIZED CUTTING OF WIRES DOES NOT OCCUR
 - HEAVY CRANES OR SIMILAR HEAVY LOADS SHALL BE SET BACK A MINIMUM DISTANCE EQUAL TO THE WALL HEIGHT FROM THE WALL FACE (EXAMPLE: 18-FOOT SET BACK FROM A 18-FOOT-HIGH WALL). DO NOT STOCKPILE SOIL ON THE MSE WALLS.
 - IF THERE ARE BOTTOM OF WALL ELEVATION DISCREPANCIES, NOTIFY THE ENGINEER SO THAT REDESIGN CAN BE CONSIDERED.

SUPPLIED REINFORCEMENT QUANTITIES				
BASE LENGTH	CAP MAT W7XW3.5 (8"X12")	PRONGLESS MAT W7XW3.5 (8"X12")	STANDARD MAT W7XW3.5 (8"X10.5")	STANDARD MAT W7XW4 (8"X21")
20'	40	40		
19.25'				280
18'	54	54		
17.5'			43	292
13'	11	11		
12.25'			22	33
11'	5	5		
10.5'			5	15
9'	22	22		
8.75'				52
WALL FACE SUPPLIED	13,984 SF			
BACKING MATS (2'-0" HIGH)	891 EA			
FILTER FABRIC (7'-6" WIDE)	7,128 LF			
HOG RINGS	21,000 EA			
PLIERS	7 EA			

J:\0114 Russian River Campground PREPARED 12-12-2022.dwg

12/12/2022 2:47 PM

REV.	DATE	BY	DESCRIPTION
0	9/26/2022	RGV	ISSUED FOR HILFIKER REVIEW
1	9/27/2022	RGV	ISSUED FOR OWNER REVIEW
2	10/17/2022	RGV	ISSUED FOR OWNER REVIEW
3	12/12/2022	RGV	ISSUED FOR OWNER REVIEW

HILFIKER RETAINING WALLS



1902 Hilfiker Lane
Eureka, CA 95603-8711
TOLL-FREE 800.762.8962
PH 707.443.5093 FAX 707.443.2891
WEB SITE www.hilfiker.com E-MAIL info@hilfiker.com

SHANNON & WILSON, INC.
GEOTECHNICAL AND ENVIRONMENTAL CONSULTANTS

5260 Chinden Blvd.
Boise, ID 83714
(208) 658-8700
Fax: (208) 658-8703

NOTES, QUANTITIES	
FWHA WFL	COOPER LANDING, AK

DWG DATE:	11 DEC 2022
HRW NO.:	220711CW
SHEET	1
OF	10

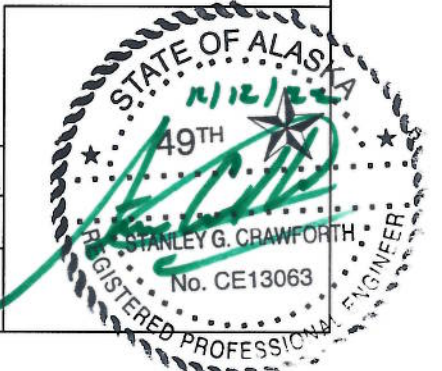

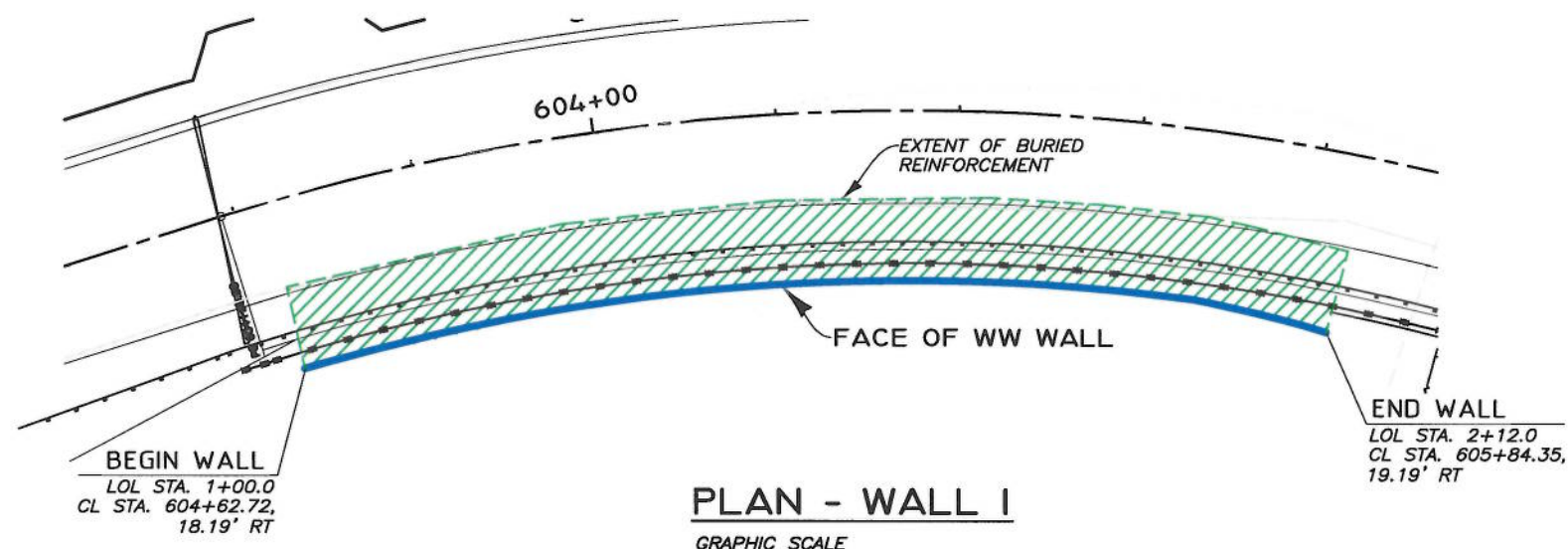
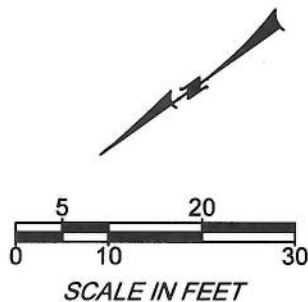

PLAN - WALL I

GRAPHIC SCALE

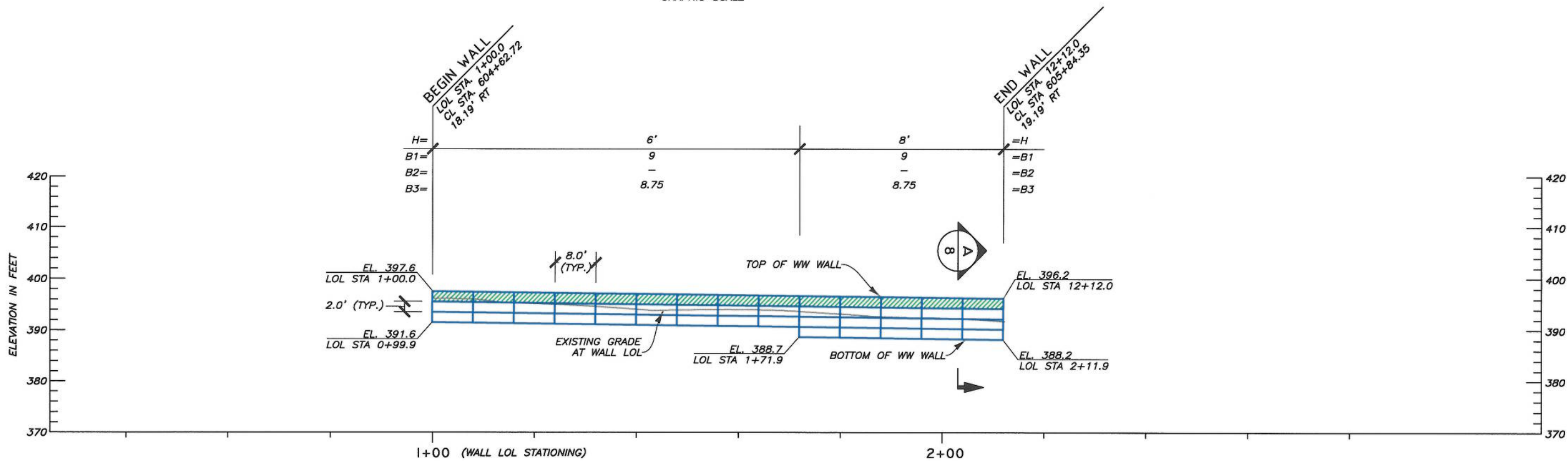

DEVELOPED ELEVATION - WALL I (FRONT FACE)

GRAPHIC SCALE

LEGEND

	B1	8"x12", W7xW3.5-HDG	LOL	LAYOUT LINE
	B2	8"x10.5", W7xW3.5-HDG	H	WALL HEIGHT (BOTTOM MAT TO CAP MAT)
	B3	8"x21", W7xW4-HDG	B	MAT LENGTH (FT)
	WW		WW	WELDED WIRE

I:\0114 Russian River Campground PREPARED 12-12-2022.dwg

12/12/2022 2:47 PM

THE DESIGN CONTAINED ON THESE DRAWINGS IS BASED ON INFORMATION PROVIDED BY THE OWNER. ON THE BASIS OF THIS INFORMATION, THE HILFIKER COMPANY HAS DESIGNED, AND IS RESPONSIBLE FOR THE INTERNAL STABILITY OF THE STRUCTURE ONLY. EXTERNAL STABILITY, INCLUDING FOUNDATION AND SLOPE STABILITY, IS THE RESPONSIBILITY OF THE OWNER.

REV.	DATE	BY	DESCRIPTION
0	9/26/2022	RGV	ISSUED FOR HILFIKER REVIEW
1	9/27/2022	RGV	ISSUED FOR OWNER REVIEW
2	10/17/2022	RGV	ISSUED FOR OWNER REVIEW
3	12/12/2022	RGV	ISSUED FOR OWNER REVIEW

CADD:	RGV
DESIGNED:	RGV
CHECKED:	SGC

HILFIKER RETAINING WALLS



1902 HilfiKER Lane
Eureka, CA 95503-6711
TOLL-FREE 800.762.8962
PH 707.443.5093 FAX 707.443.2891
WEBSITE www.hilfiKER.com E-MAIL info@hilfiKER.com



SHANNON & WILSON, INC.
GEOTECHNICAL AND ENVIRONMENTAL CONSULTANTS

5260 Chinden Blvd.
Boise, ID 83714
(208) 658-8700
Fax: (208) 658-8703

PLAN & ELEVATION

WW WALLS
RUSSIAN RIVER CAMPGROUND
ACCESS PHASE 2

FHWA WFL COOPER LANDING, AK

DWG DATE:	11 DEC 2022
HRW NO.:	220711CW
SHEET	2
OF 10	

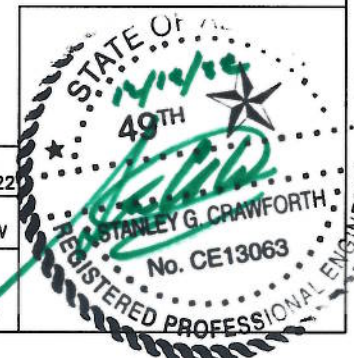

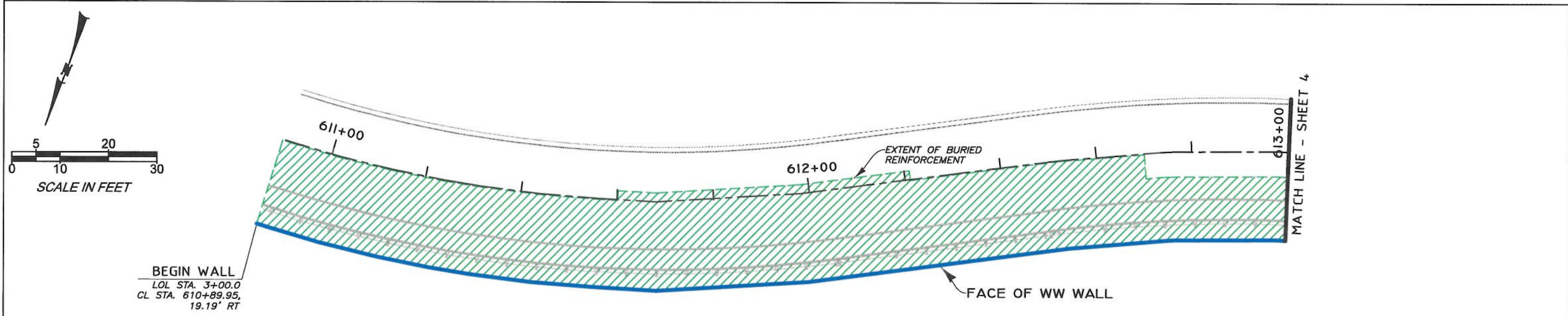

PLAN - WALL 2
GRAPHIC SCALE

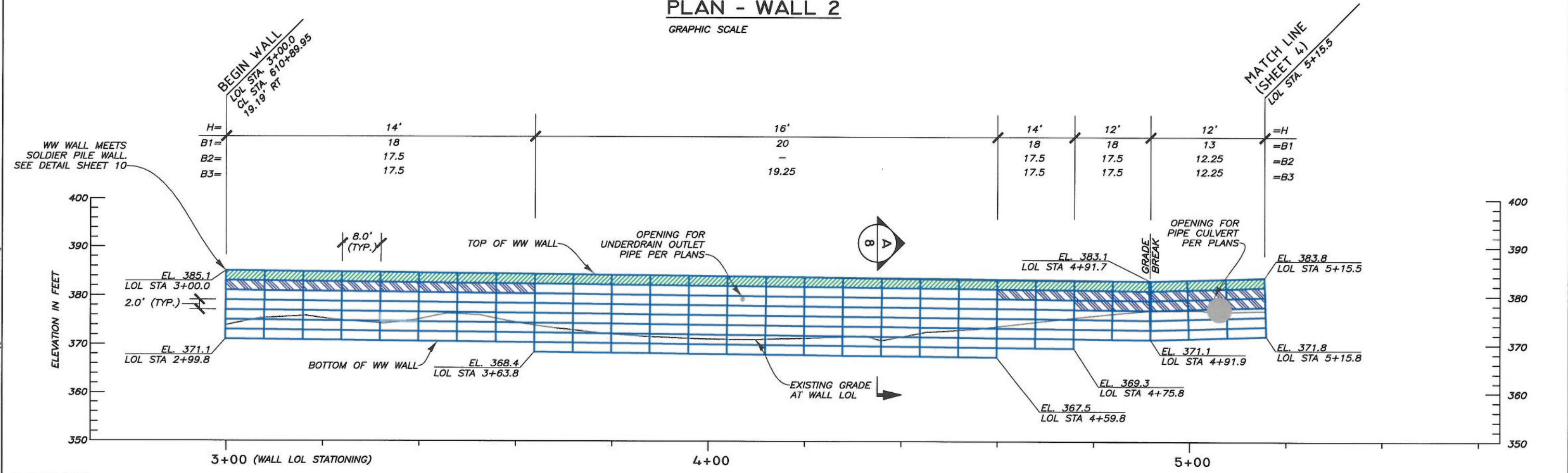

DEVELOPED ELEVATION - WALL 2 (FRONT FACE)
GRAPHIC SCALE

LEGEND

	B1	8"x12", W7xW3.5-HDG	LOL	LAYOUT LINE
	B2	8"x10.5", W7xW3.5-HDG	H	WALL HEIGHT (BOTTOM MAT TO CAP MAT)
	B3	8"x21", W7xW4-HDG	B	MAT LENGTH (FT)
	WW		WW	WELDED WIRE

1/10/14 Russian River Campground PREPARED 12-12-2022.dwg

12/12/2022 2:47 PM

THE DESIGN CONTAINED ON THESE DRAWINGS IS BASED ON INFORMATION PROVIDED BY THE OWNER. ON THE BASIS OF THIS INFORMATION, THE HILFIKER COMPANY HAS DESIGNED, AND IS RESPONSIBLE FOR THE INTERNAL STABILITY OF THE STRUCTURE ONLY. EXTERNAL STABILITY, INCLUDING FOUNDATION AND SLOPE STABILITY, IS THE RESPONSIBILITY OF THE OWNER.

REV.	DATE	BY	DESCRIPTION	CADD:
0	9/26/2022	RGV	ISSUED FOR HILFIKER REVIEW	RGV
1	9/27/2022	RGV	ISSUED FOR OWNER REVIEW	DESIGNED: RGV
2	10/17/2022	RGV	ISSUED FOR OWNER REVIEW	CHECKED: SGC
3	12/12/2022	RGV	ISSUED FOR OWNER REVIEW	

HILFIKER RETAINING WALLS

1902 HilfiKER Lane
Eureka, CA 95603-8711
TOLL-FREE 800.762.8962
PH 707.443.5093 FAX 707.443.2891
WEBSITE www.hilfiKER.com E-MAIL info@hilfiKER.com

SHANNON & WILSON, INC.
GEOTECHNICAL AND ENVIRONMENTAL CONSULTANTS

5260 Chinden Blvd.
Boise, ID 83714
(208) 658-8700
Fax: (208) 658-8703

PLAN & ELEVATION		DWG DATE: 11 DEC 2022
WW WALLS		HRW NO.: 220711CW
RUSSIAN RIVER CAMPGROUND ACCESS PHASE 2		SHEET 3 OF 10
FHWA WFL	COOPER LANDING, AK	

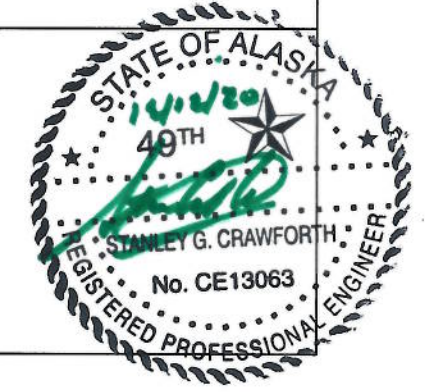

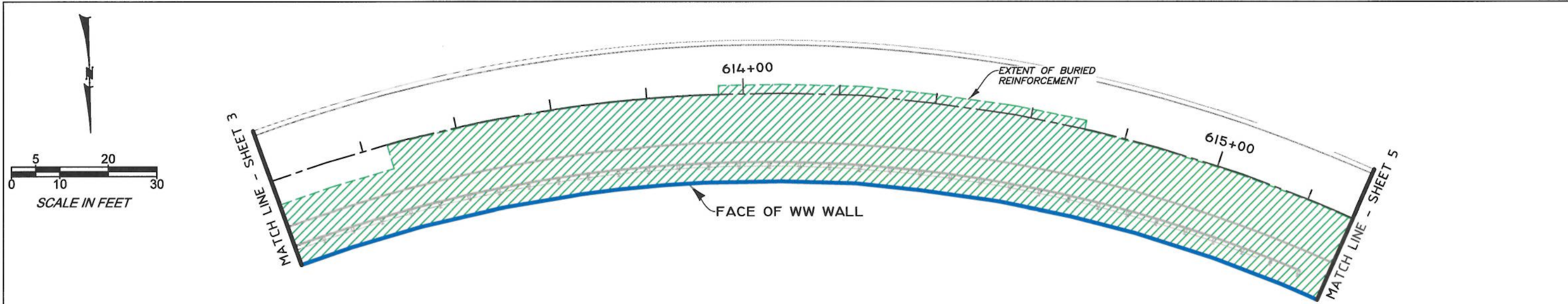

PLAN - WALL 2
GRAPHIC SCALE

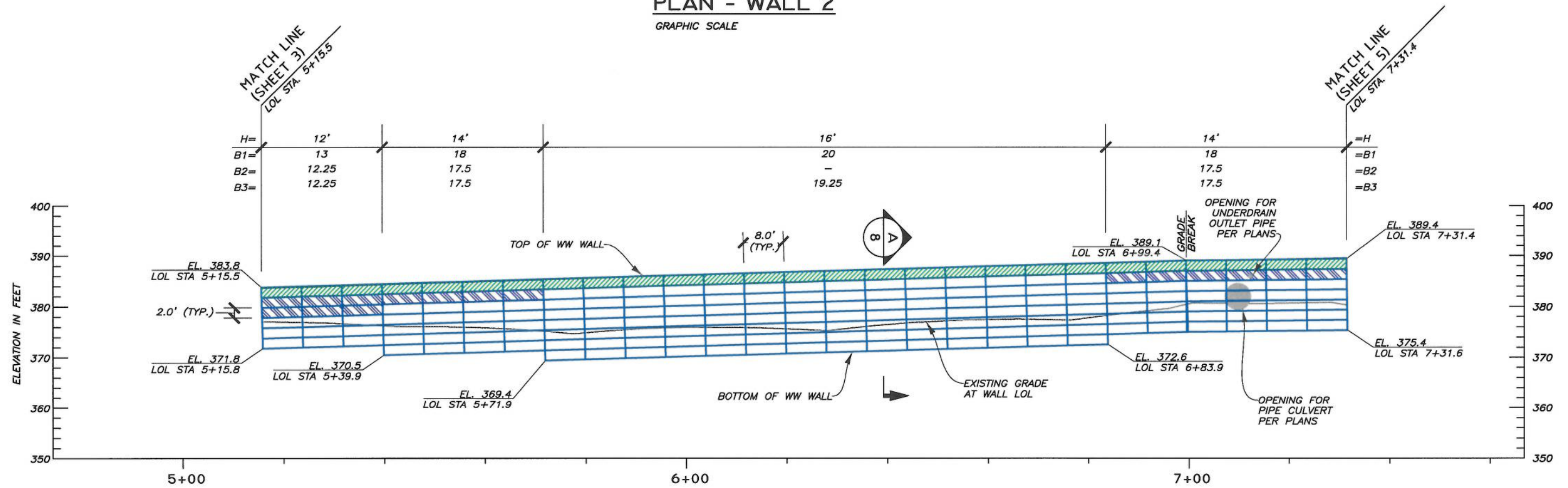

DEVELOPED ELEVATION - WALL 2 (FRONT FACE)
GRAPHIC SCALE

LEGEND

	B1	8"x12", W7xW3.5-HDG	LOL	LAYOUT LINE
	B2	8"x10.5", W7xW3.5-HDG	H	WALL HEIGHT (BOTTOM MAT TO CAP MAT)
	B3	8"x21", W7xW4-HDG	B	MAT LENGTH (FT)
			WW	WELDED WIRE

I:\0114 Russian River Campground PREPARED 12-12-2022.dwg

12/12/2022 2:47 PM

REV.	DATE	BY	DESCRIPTION	CADD:
0	9/26/2022	RGV	ISSUED FOR HILFIKER REVIEW	RGV
1	9/27/2022	RGV	ISSUED FOR OWNER REVIEW	DESIGNED: RGV
2	10/17/2022	RGV	ISSUED FOR OWNER REVIEW	CHECKED: SGC
3	12/12/2022	RGV	ISSUED FOR OWNER REVIEW	

HILFIKER RETAINING WALLS

1902 HilfiKER Lane
Eureka, CA 95503-5711
TOLL-FREE 800.762.8962
PH 707.443.5093 FAX 707.443.2891
WEBSITE www.hilfiKER.com E-MAIL info@hilfiKER.com

SHANNON & WILSON, INC.
GEOTECHNICAL AND ENVIRONMENTAL CONSULTANTS

5260 Chinden Blvd.
Boise, ID 83714
(208) 658-8700
Fax: (208) 658-8703

PLAN & ELEVATION	DWG DATE: 11 DEC 2022
WW WALLS	HRW NO.: 220711CW
RUSSIAN RIVER CAMPGROUND ACCESS PHASE 2	SHEET 4 OF 10
FHWA WFL COOPER LANDING, AK	



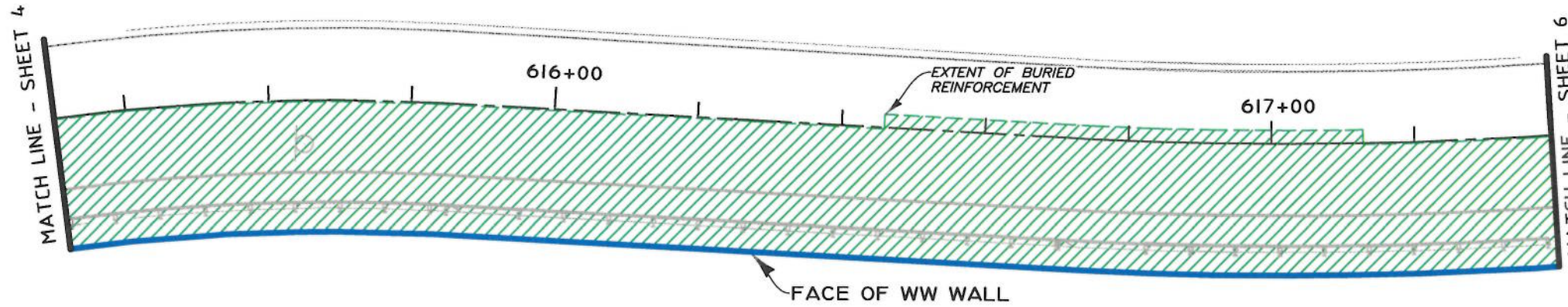
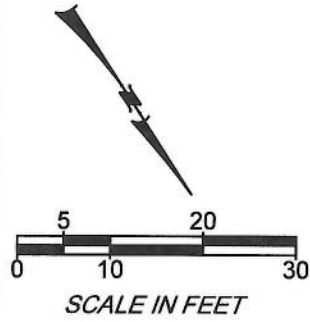

PLAN - WALL 2
GRAPHIC SCALE

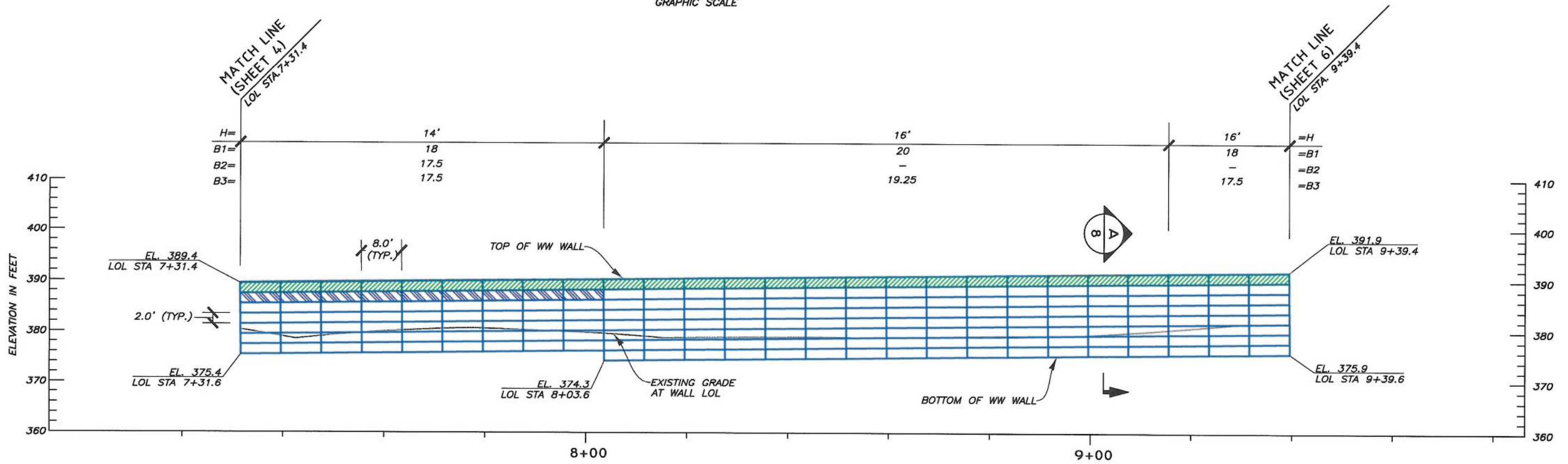

DEVELOPED ELEVATION - WALL 2 (FRONT FACE)
GRAPHIC SCALE

LEGEND			
	B1 8"x12", W7xW3.5-HDG	LOL	LAYOUT LINE
	B2 8"x10.5", W7xW3.5-HDG	H	WALL HEIGHT (BOTTOM MAT TO CAP MAT)
	B3 8"x21", W7xW4-HDG	B	MAT LENGTH (FT)
		WW	WELDED WIRE

1/10/24 Russian River Campground PREPARED 12-12-2022.dwg

12/12/2022 2:47 PM

REV.	DATE	BY	DESCRIPTION	CADD:
0	9/26/2022	RGV	ISSUED FOR HILFIKER REVIEW	RGV
1	9/27/2022	RGV	ISSUED FOR OWNER REVIEW	DESIGNED: RGV
2	10/17/2022	RGV	ISSUED FOR OWNER REVIEW	CHECKED: SGC
3	12/12/2022	RGV	ISSUED FOR OWNER REVIEW	

HILFIKER RETAINING WALLS

1902 Hilfiker Lane
Eureka, CA 95603-5711
TOLL-FREE 800.762.8962
PH 707.443.3093 Fax 707.443.2891
WEBSITE www.hilfiker.com E-MAIL info@hilfiker.com

SHANNON & WILSON, INC.
GEOTECHNICAL AND ENVIRONMENTAL CONSULTANTS

5260 Chinden Blvd.
Boise, ID 83714
(208) 658-8700
Fax: (208) 658-8703

PLAN & ELEVATION		DWG DATE:
WW WALLS		11 DEC 2022
RUSSIAN RIVER CAMPGROUND		HRW NO.:
ACCESS PHASE 2		220711CW
FHWA WFL COOPER LANDING, AK		SHEET
		5
		OF 10



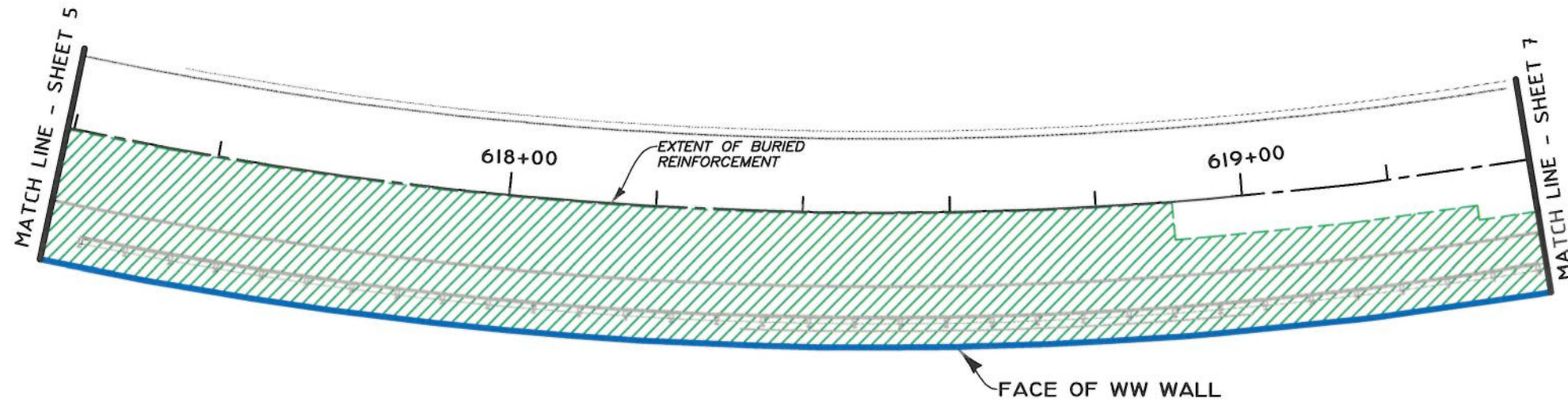
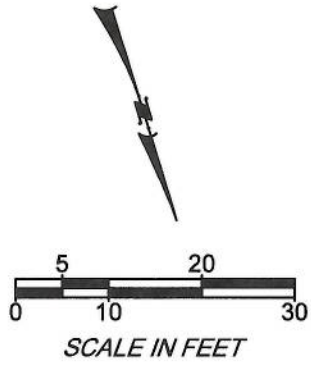

PLAN - WALL 2

GRAPHIC SCALE

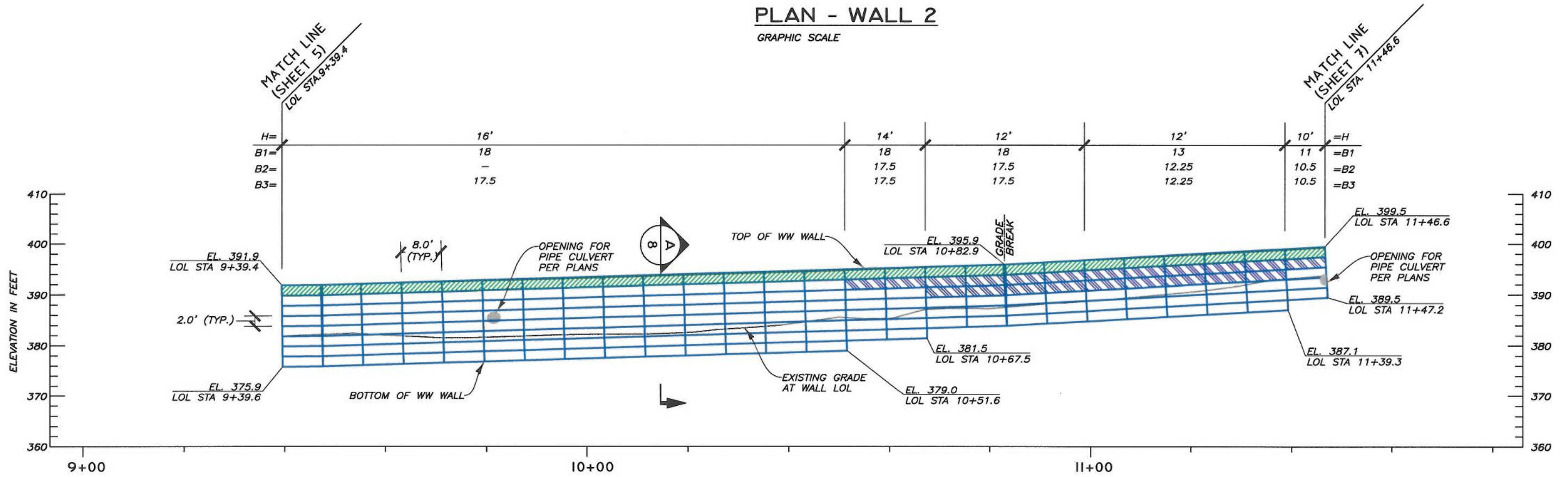

DEVELOPED ELEVATION - WALL 2 (FRONT FACE)

GRAPHIC SCALE

LEGEND

	B1	8"x12", W7xW3.5-HDG	LOL	LAYOUT LINE
	B2	8"x10.5", W7xW3.5-HDG	H	WALL HEIGHT (BOTTOM MAT TO CAP MAT)
	B3	8"x21", W7xW4-HDG	B	MAT LENGTH (FT)
			WW	WELDED WIRE

110114 Russian River Campground PREPARED 12-12-2022.dwg

12/12/2022 2:47 PM

REV.	DATE	BY	DESCRIPTION	CADD:
0	9/26/2022	RGV	ISSUED FOR HILFIKER REVIEW	RGV
1	9/27/2022	RGV	ISSUED FOR OWNER REVIEW	DESIGNED: RGV
2	10/17/2022	RGV	ISSUED FOR OWNER REVIEW	CHECKED: SGC
3	12/12/2022	RGV	ISSUED FOR OWNER REVIEW	

HILFIKER RETAINING WALLS

1902 HilfiKER Lane
Eureka, CA 95603-6711
TOLL-FREE 800.762.8962
PH 707.443.5093 FAX 707.443.2891
WEBSITE www.hilfiKER.com E-MAIL info@hilfiKER.com

SHANNON & WILSON, INC.
GEOTECHNICAL AND ENVIRONMENTAL CONSULTANTS

5260 Chinden Blvd.
Boise, ID 83714
(208) 658-8700
Fax: (208) 658-8703

PLAN & ELEVATION	
WW WALLS	
RUSSIAN RIVER CAMPGROUND ACCESS PHASE 2	
FHWA WFL	COOPER LANDING, AK

DWG DATE:	11 DEC 2022
HRW NO.:	220711CW
SHEET	6
OF 10	



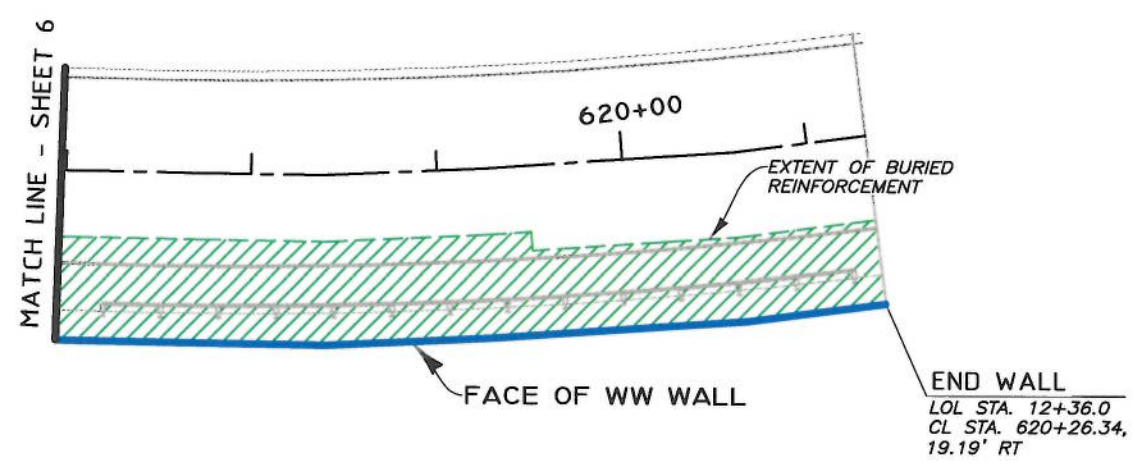
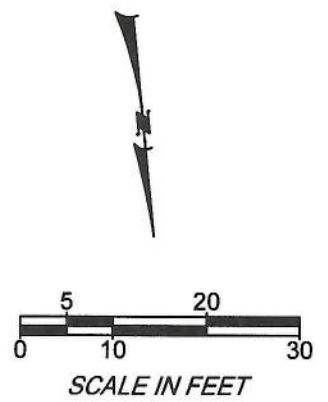

PLAN - WALL 2
GRAPHIC SCALE

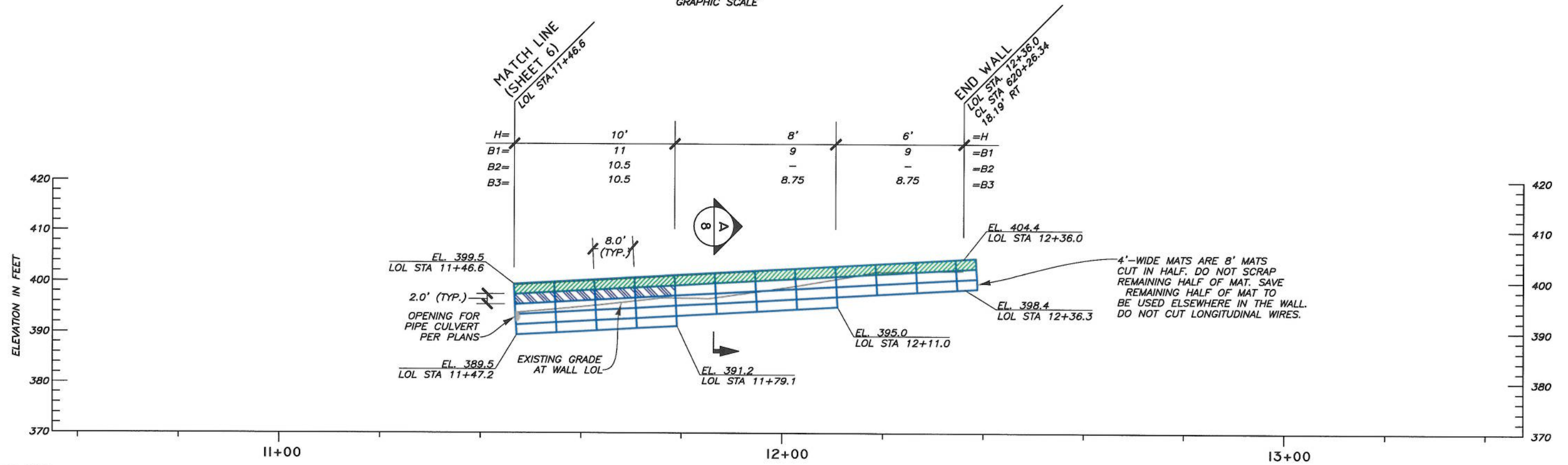

DEVELOPED ELEVATION - WALL 2 (FRONT FACE)
GRAPHIC SCALE

LEGEND

	B1	8"x12", W7xW3.5-HDG	LOL	LAYOUT LINE
	B2	8"x10.5", W7xW3.5-HDG	H	WALL HEIGHT (BOTTOM MAT TO CAP MAT)
	B3	8"x21", W7xW4-HDG	B	MAT LENGTH (FT)
			WW	WELDED WIRE

11/11/2022 2:47 PM

12/12/2022 2:47 PM

THE DESIGN CONTAINED ON THESE DRAWINGS IS BASED ON INFORMATION PROVIDED BY THE OWNER. ON THE BASIS OF THIS INFORMATION, THE HILFIKER COMPANY HAS DESIGNED, AND IS RESPONSIBLE FOR THE INTERNAL STABILITY OF THE STRUCTURE ONLY. EXTERNAL STABILITY, INCLUDING FOUNDATION AND SLOPE STABILITY, IS THE RESPONSIBILITY OF THE OWNER.

REV.	DATE	BY	DESCRIPTION	CADD:
0	9/26/2022	RGV	ISSUED FOR HILFIKER REVIEW	RGV
1	9/27/2022	RGV	ISSUED FOR OWNER REVIEW	DESIGNED: RGV
2	10/17/2022	RGV	ISSUED FOR OWNER REVIEW	CHECKED: SGC
3	12/12/2022	RGV	ISSUED FOR OWNER REVIEW	

HILFIKER RETAINING WALLS

1902 HilfiKER Lane
Eureka, CA 95603-6711
TOLL-FREE 800.762.8962
PH 707.443.5093 FAX 707.443.2891
WEBSITE www.hilfiKER.com E-MAIL info@hilfiKER.com

SHANNON & WILSON, INC.
GEOTECHNICAL AND ENVIRONMENTAL CONSULTANTS

5260 Chinden Blvd.
Boise, ID 83714
(208) 658-8700
Fax: (208) 658-8703

PLAN & ELEVATION	DWG DATE: 11 DEC 2022
WW WALLS	HRW NO.: 220711CW
RUSSIAN RIVER CAMPGROUND ACCESS PHASE 2	SHEET 7
FHWA WFL COOPER LANDING, AK	OF 10



110114 Russian River Campground PREPARED 12-12-2022.dwg

12/12/2022 2:47 PM

RGV

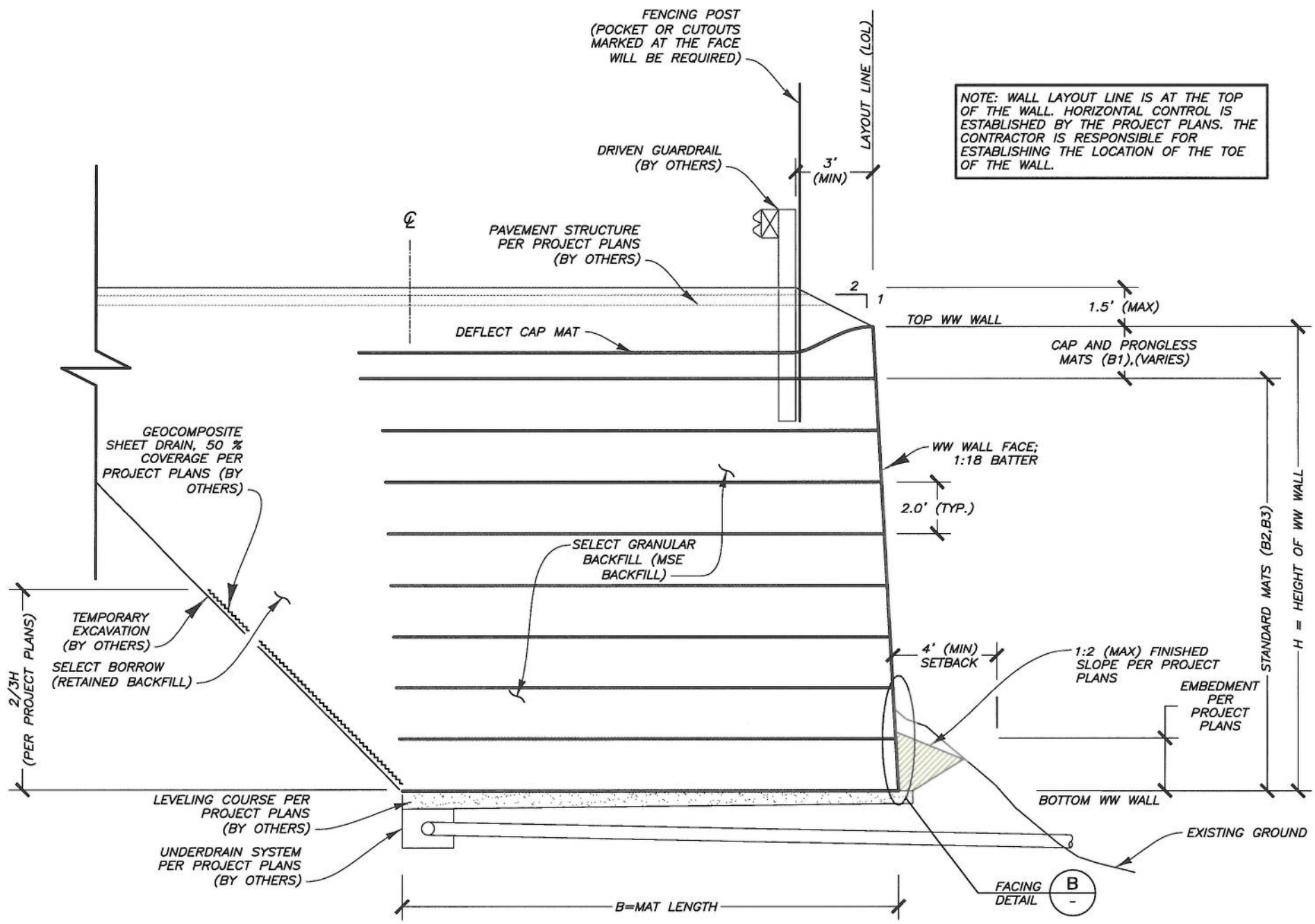

TYPICAL SECTION A
NOT TO SCALE

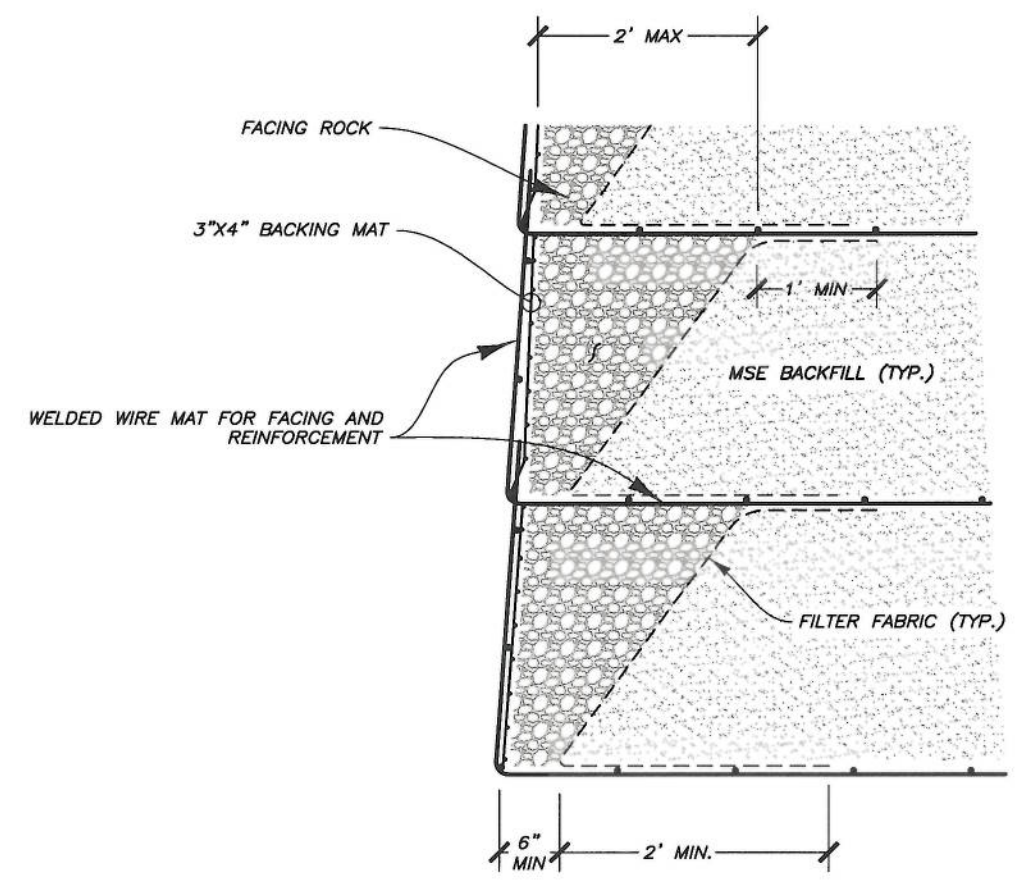

FACING DETAIL B
NOT TO SCALE

REV.	DATE	BY	DESCRIPTION
0	9/26/2022	RGV	ISSUED FOR HILFIKER REVIEW
1	9/27/2022	RGV	ISSUED FOR OWNER REVIEW
2	10/17/2022	RGV	ISSUED FOR OWNER REVIEW
3	12/12/2022	RGV	ISSUED FOR OWNER REVIEW

CADD: RGV
DESIGNED: RGV
CHECKED: SGC

HILFIKER RETAINING WALLS

1902 Hilfiker Lane
Eureka, CA 95603-6711
TOLL-FREE 800.762.8962
PH 707.443.5093 FAX 707.443.2891
WEBSITE www.hilfiker.com E-MAIL info@hilfiker.com

SHANNON & WILSON, INC.
GEOTECHNICAL AND ENVIRONMENTAL CONSULTANTS

5260 Chinden Blvd.
Boise, ID 83714
(208) 658-8700
Fax: (208) 658-8703

SECTION & DETAIL	
WW WALLS	RUSSIAN RIVER CAMPGROUND ACCESS PHASE 2
FHWA WFL	COOPER LANDING, AK

DWG DATE:	11 DEC 2022
HRW NO.:	220711CW
SHEET	8
OF 10	

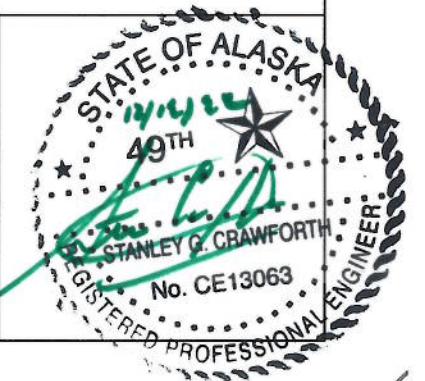

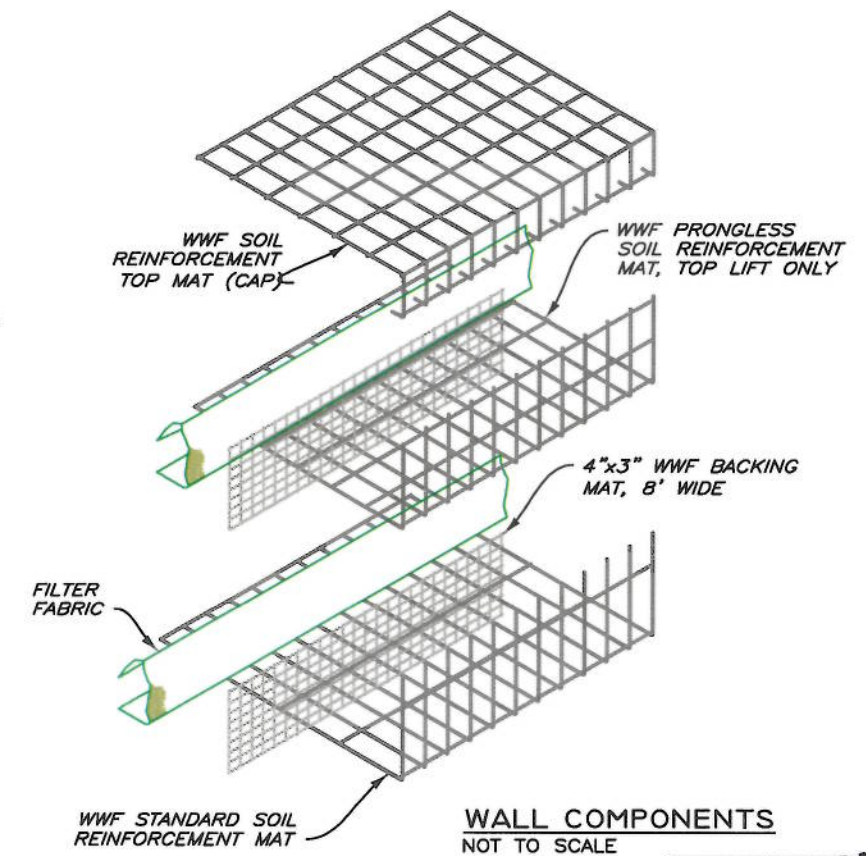
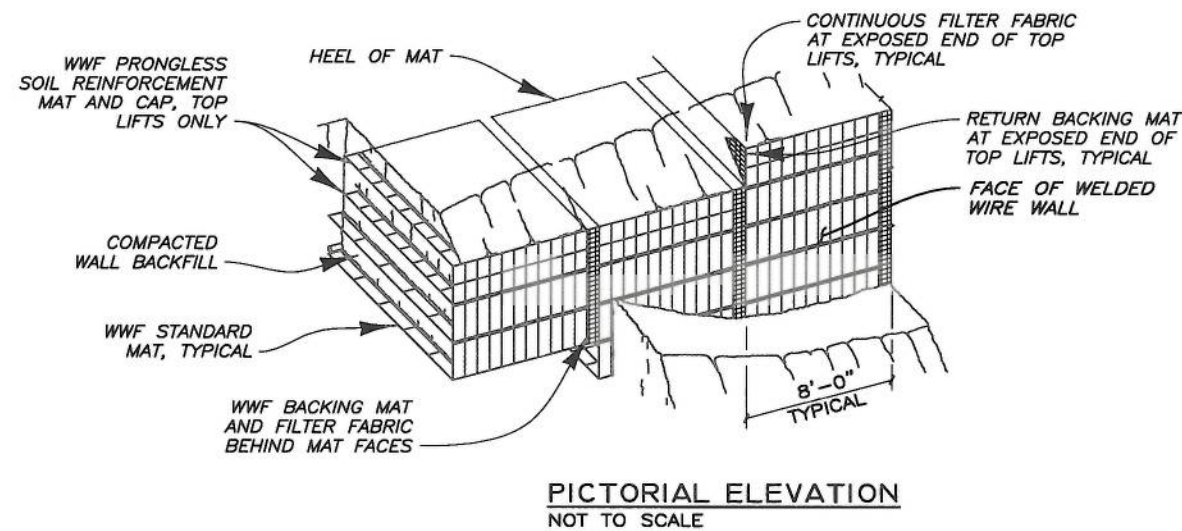
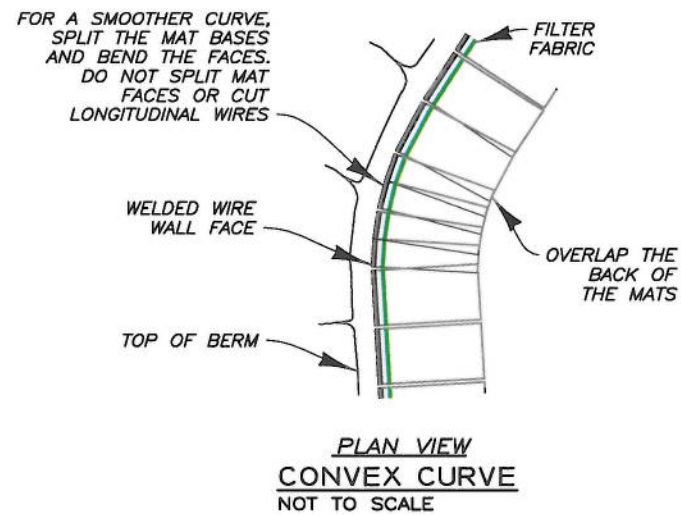
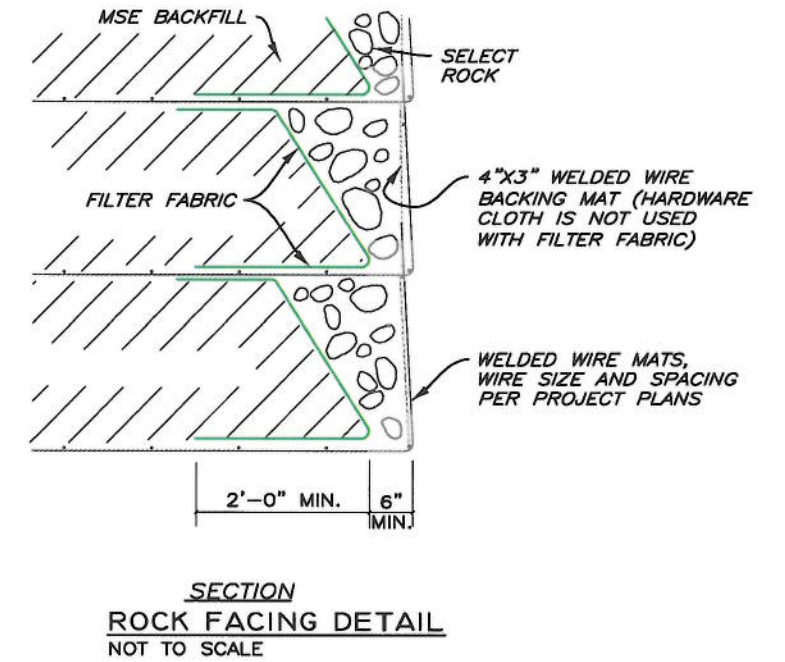
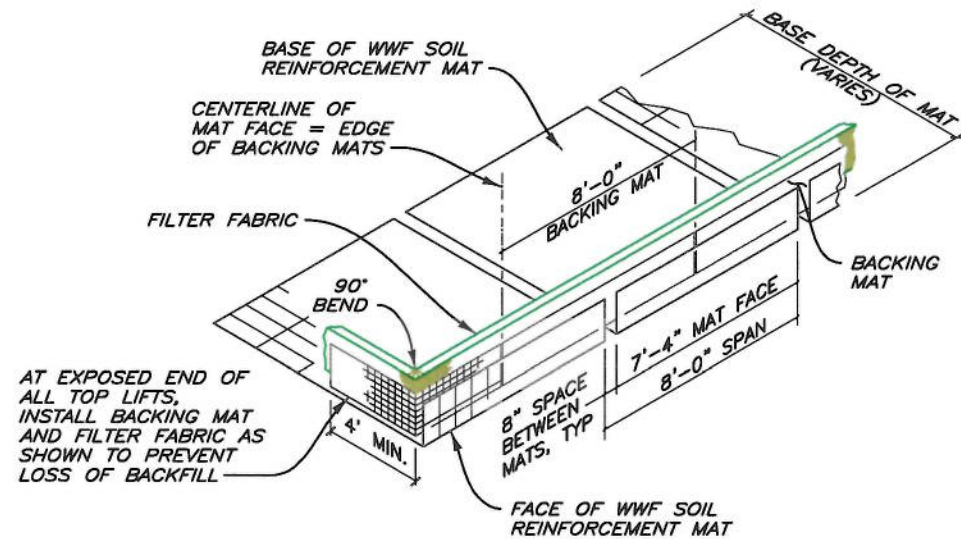
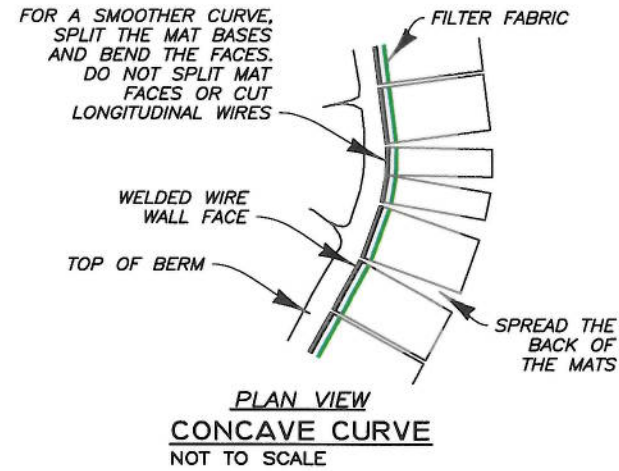

J:\0114 Russian River Campground PREPARED 12-12-2022.dwg

12/12/2022 2:47 PM RGV

THE DESIGN CONTAINED ON THESE DRAWINGS IS BASED ON INFORMATION PROVIDED BY THE OWNER. ON THE BASIS OF THIS INFORMATION, THE HILFIKER COMPANY HAS DESIGNED, AND IS RESPONSIBLE FOR THE INTERNAL STABILITY OF THE STRUCTURE ONLY. EXTERNAL STABILITY, INCLUDING FOUNDATION AND SLOPE STABILITY, IS THE RESPONSIBILITY OF THE OWNER.

REV.	DATE	BY	DESCRIPTION
0	9/26/2022	RGV	ISSUED FOR HILFIKER REVIEW
1	9/27/2022	RGV	ISSUED FOR OWNER REVIEW
2	10/17/2022	RGV	ISSUED FOR OWNER REVIEW
3	12/12/2022	RGV	ISSUED FOR OWNER REVIEW

CADD: RGV
DESIGNED: RGV
CHECKED: SGC

HILFIKER RETAINING WALLS



1902 HilfiKER Lane
Eureka, CA 95503-6711
TOLL-FREE 800.762.8962
PH 707.443.5093 FAX 707.443.2891
WEB SITE www.hilfiKER.com E-MAIL info@hilfiKER.com



SHANNON & WILSON, INC.
GEOTECHNICAL AND ENVIRONMENTAL CONSULTANTS

5260 Chinden Blvd.
Boise, ID 83714
(208) 658-8700
Fax: (208) 658-8703

DETAILS	
WW WALLS	RUSSIAN RIVER CAMPGROUND ACCESS PHASE 2
FHWA WFL	COOPER LANDING, AK

DWG DATE:	11 DEC 2022
HRW NO.:	220711CW
SHEET	9
OF	10

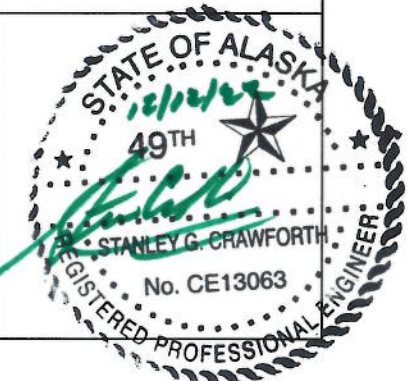

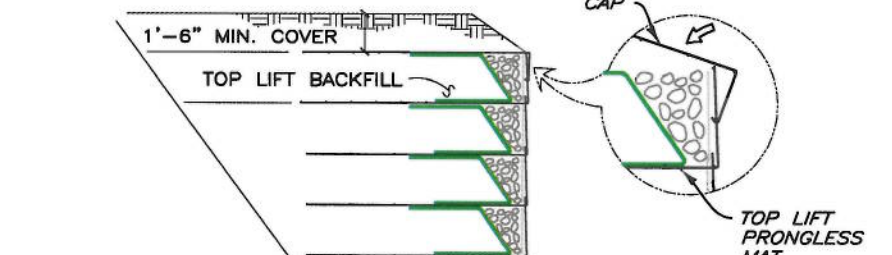
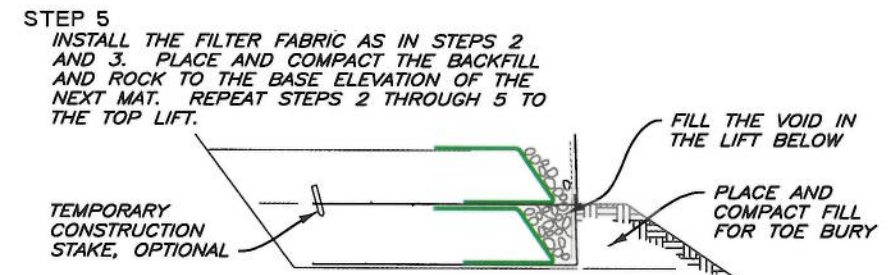
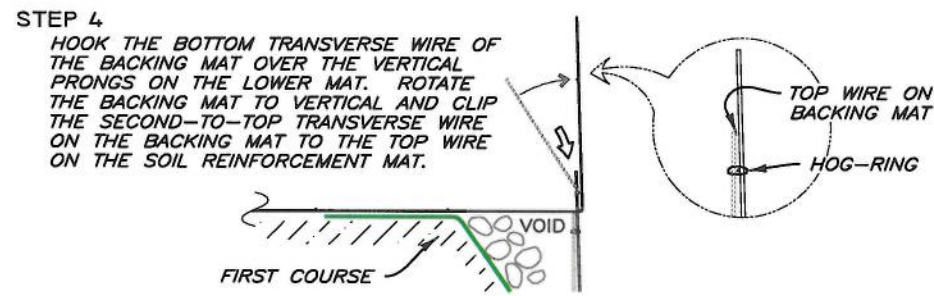
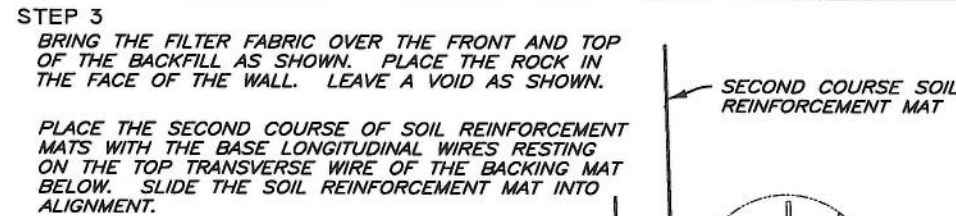
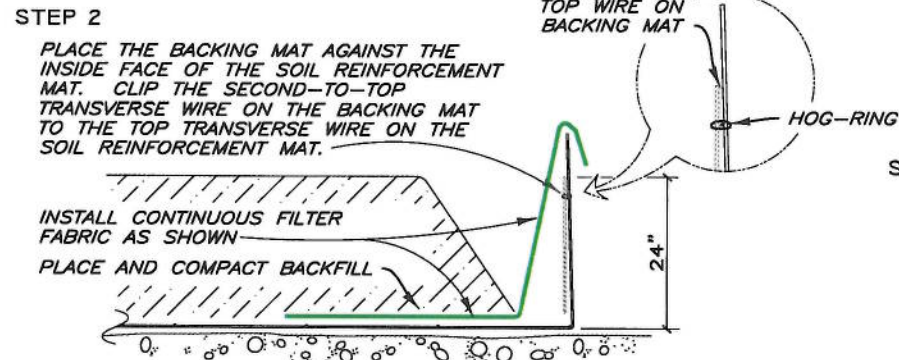
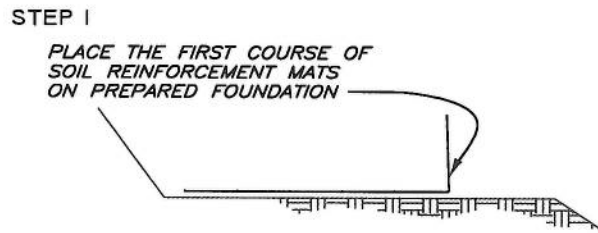

CONSTRUCTION SEQUENCE
NOT TO SCALE

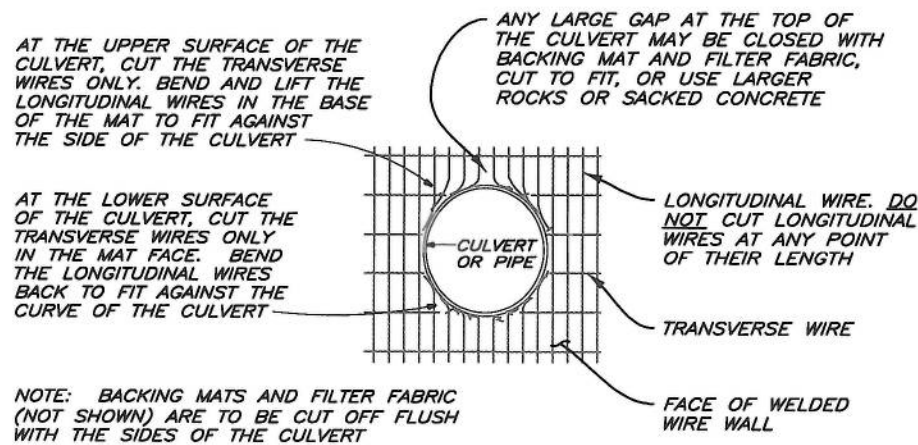

ELEVATION
CULVERT THRU WALL FACE
NOT TO SCALE

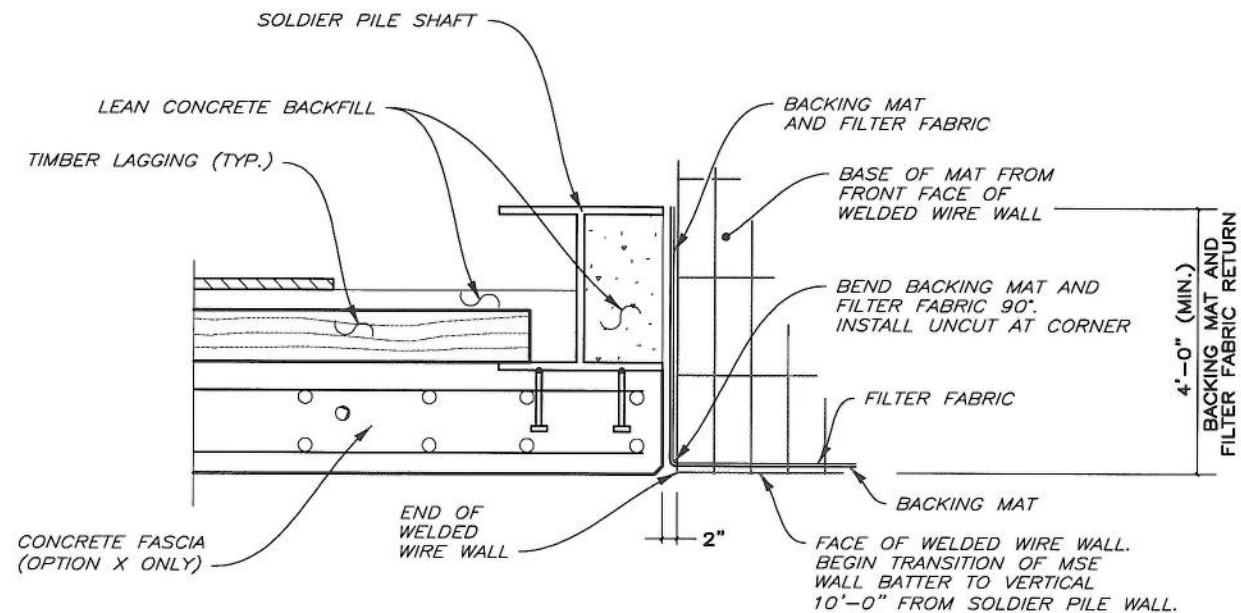

WELDED WIRE WALL END AT SOLDIER PILE WALL
NOT TO SCALE

110114 Russian River Campground PREPARED 12-12-2022.dwg

12/12/2022 2:47 PM

REV.	DATE	BY	DESCRIPTION	CADD:
0	9/26/2022	RGV	ISSUED FOR HILFIKER REVIEW	RGV
1	9/27/2022	RGV	ISSUED FOR OWNER REVIEW	DESIGNED: RGV
2	10/17/2022	RGV	ISSUED FOR OWNER REVIEW	CHECKED: SGC
3	12/12/2022	RGV	ISSUED FOR OWNER REVIEW	

HILFIKER RETAINING WALLS
1902 Hilfiaker Lane
Eureka, CA 95503-5711
TOLL-FREE 800.762.8962
PH 707.443.3093 FAX 707.443.2891
WEB SITE www.hilfiaker.com E-MAIL info@hilfiaker.com

SHANNON & WILSON, INC.
GEOTECHNICAL AND ENVIRONMENTAL CONSULTANTS
5260 Chinden Blvd.
Boise, ID 83714
(208) 658-8700
Fax: (208) 658-8703

SEQUENCE & DETAIL		DWG DATE:
WW WALLS		11 DEC 2022
RUSSIAN RIVER CAMPGROUND		HRW NO.:
ACCESS PHASE 2		220711CW
FHWA WFL	COOPER LANDING, AK	SHEET
		10
		OF 10

