

TYPICAL GABION
NOT TO SCALE

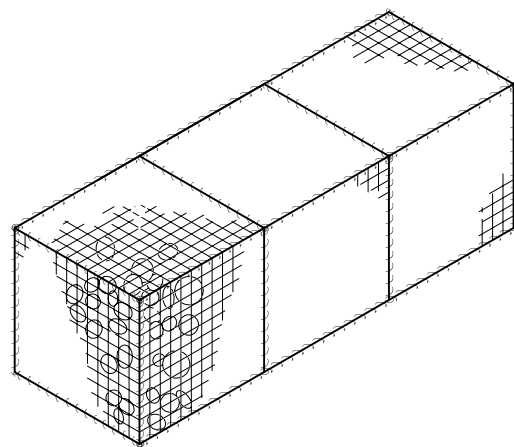

TYPICAL ASSEMBLED GABION
NOT TO SCALE

CRIMP ENDS OF SPIRAL CLOSED

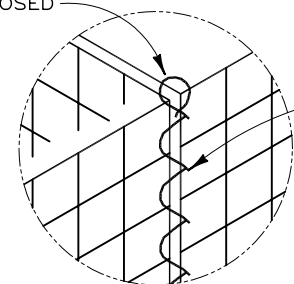

9 GA SPIRAL BINDER CONNECTS GABIONS TOGETHER

OPTIONAL 13 GA TIE WIRE, ONE HITCH AT 3" SPACING

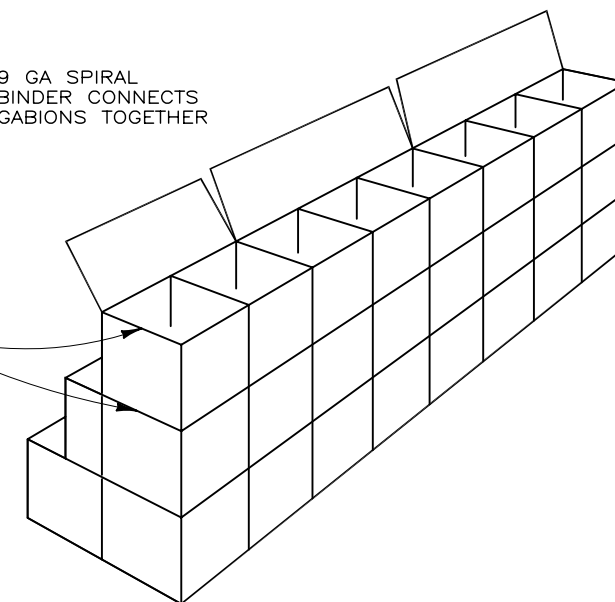
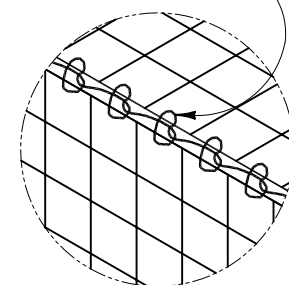

ASSEMBLY DETAILS - VERTICAL WALL
NOT TO SCALE

NOTES

- GABION SIZES ARE EXPRESSED IN FEET.
- GABIONS WHICH ARE TO BE CONNECTED TOGETHER SIDE-TO-SIDE OR END-TO-END, MAY BE PROVIDED OPEN-SIDED OR OPEN-ENDED AS SHOWN TO REDUCE WEIGHT, COST, AND ASSEMBLY TIME.
- GABIONS ARE MANUFACTURED OF 3"x3" WELDED WIRE MESH, 9 GA. WITH 0.9 OZ/SF ZINC COATING.

PROJECT-SPECIFIC NOTES:

- REFERENCE DRAWINGS: PLANS FROM SITE WORKSHOP, LLC LANDSCAPE ARCHITECTURE DATED 14 SEPTEMBER 2009. SHEETS T1.00, L1.10, 1.11, 2.10, 2.11, 3.10, 3.11, 3.12, AND 3.20.
- IT IS ASSUMED THAT ALL MATERIALS, BACKFILL AND CONSTRUCTION METHODS FOR HILFIKER M.S.E. WALLS AND/OR GABIONS WILL CONFORM TO HILFIKER'S SPECIFICATIONS AND/OR THOSE OF THE HILFIKER ENGINEERING CONSULTANT.
- THIS IS NOT AN ENGINEERED SUBMITTAL. ALL INFORMATION HEREON IS DERIVED FROM THE REFERENCE DRAWINGS, AND IS SUBJECT TO GEOMETRIC AND GEOTECHNICAL CONFIRMATION. THE APPLICABLE HILFIKER CONSTRUCTION GUIDE AND SPECIFICATIONS ARE AN INTEGRAL PART OF THIS SUBMITTAL.
- UPON ENGINEERED DESIGN, HILFIKER RETAINING WALLS SHALL BE RESPONSIBLE ONLY FOR THE INTERNAL STABILITY OF THE RETAINING WALL, AND NOT FOR GLOBAL STABILITY OR FOUNDATION BEARING CAPACITY. THE OWNER/CONTRACTOR SHALL BE RESPONSIBLE FOR ALL JOB SITE DRAINAGE, SAFETY AND FALL PROTECTION PROVISIONS FOR WORKERS IN COMPLIANCE WITH OSHA AND ANY OTHER APPLICABLE REQUIREMENTS.
- WALL DESIGN SHALL REQUIRE A NON-SATURATED BACKFILL. SURFACE AND SUBSURFACE DRAINAGE CONTROL MAY BE REQUIRED TO PREVENT SATURATION OF THE BACKFILL OR TO RELIEVE HYDROSTATIC PRESSURES. DRAINAGE CONTROL SHALL BE AS SPECIFIED IN THE OWNER'S PROJECT PLANS AND SPECIFICATIONS, OR AS DIRECTED BY THE OWNER'S ENGINEER.

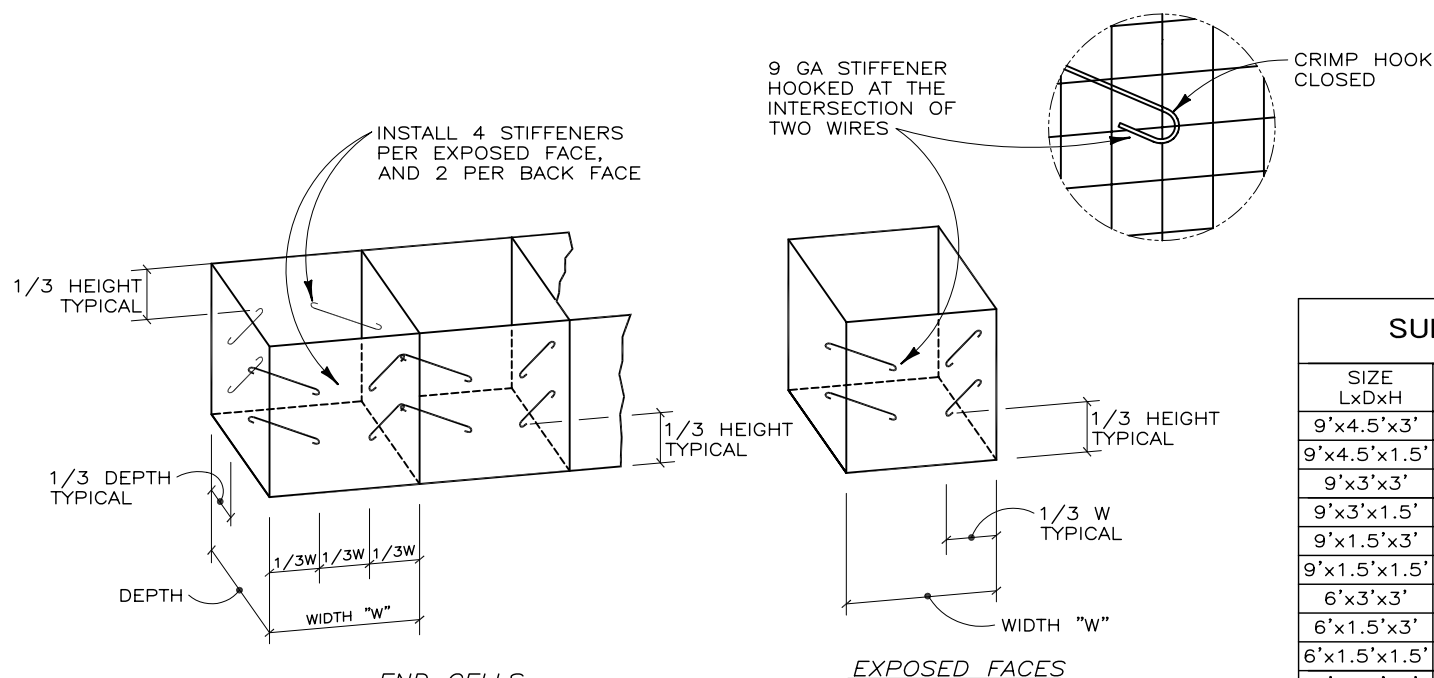

END CELLS

STIFFENER DETAILS
NOT TO SCALE

| SUPPLIED QUANTITIES | | | | |
|--|---------|---------|---------------|--|
| SIZE LxDxH | CU. YD. | # REQ'D | TOTAL CU. YD. | |
| 9'x4.5'x3' | 4.5 | 15 | 67.5 | |
| 9'x4.5'x1.5' | 2.25 | 4 | 9 | |
| 9'x3'x3' | 3 | 33 | 99 | |
| 9'x3'x1.5' | 1.5 | 6 | 9 | |
| 9'x1.5'x3' | 1.5 | 8 | 12 | |
| 9'x1.5'x1.5' | 0.75 | 1 | 0.75 | |
| 6'x3'x3' | 2 | 1 | 2 | |
| 6'x1.5'x3' | 1 | 7 | 7 | |
| 6'x1.5'x1.5' | 0.5 | 2 | 1 | |
| 3'x1.5'x3' | 0.5 | 10 | 5 | |
| 3'x1.5'x1.5' | 0.25 | 1 | 0.25 | |
| 3'x1.5'x1' | 0.17 | 1 | 0.17 | |
| ARTWELD GABIONS SUPPLIED: 212.67 CU. YD. | | | | |

080505AG DEXTER PIT PARK DEVELOPMENT

THIS DRAWING IS FURNISHED SOLELY FOR THE USE OF OR IN CONNECTION WITH THIS PROJECT AND THE PROPRIETARY INFORMATION SHOWN HEREON IS NOT TO BE TRANSMITTED TO ANY OTHER ORGANIZATION WITHOUT SPECIFIC AUTHORIZATION BY THE HILFIKER COMPANY. HILFIKER RETAINING WALLS ARE PROTECTED BY ONE OR MORE OF THE FOLLOWING PATENTS: 243,613; 243,697; 288,616; 4,117,686; 4,329,089; 4,324,508; 4,391,557; 4,505,621; 4,343,318; 4,661,023; 4,856,939; 4,929,125; 5,076,735; 5,647,695; 5,722,799; 5,733,072; 6,357,970B1; 6,874,975B2; 7,033,118B2; AND OTHERS. OTHER PATENTS PENDING (2008)

| REV. NO. | DATE | BY | DESCRIPTION |
|----------|----------|-----|---------------------------------|
| 1 | 6 APR 10 | AMJ | RECONFIGURED GABIONS ON SHEET 5 |

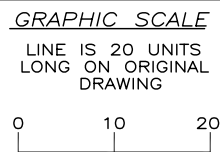

PROJ. MGR.
HKH
ENGINEER
CADD BY
AMJ

HILFIKER RETAINING WALLS

1902 Hilfiker Lane
Eureka, CA 95503-5711
TOLL-FREE 800.762.8962
PH 707.443.5093 FAX 707.443.2891
WEB SITE www.hilfiker.com E-MAIL info@hilfiker.com

DWG DATE
30 MAR 10
REVISION DATE
6 APR 10
SCALE
NOTED

SHOP DRAWING
ARTWELD GABION RETAINING WALL
DEXTER PIT PARK DEVELOPMENT
SEATTLE PARKS AND RECREATION
SEATTLE, WASHINGTON
DETAILS AND NOTES

PROJECT NO.
080505AG
SHEET
1
OF 5

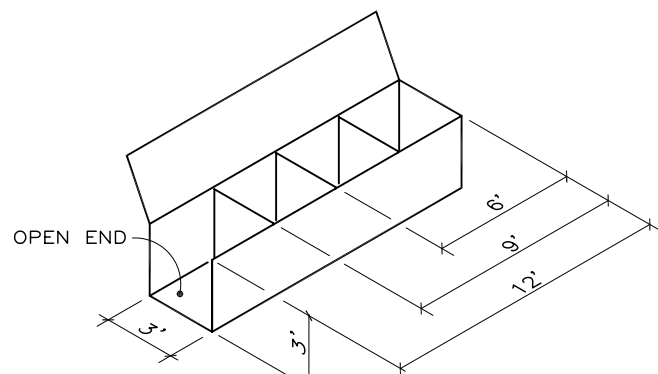

NOTE: SIZES CAN VARY
TYPICAL OPEN END
NOT TO SCALE

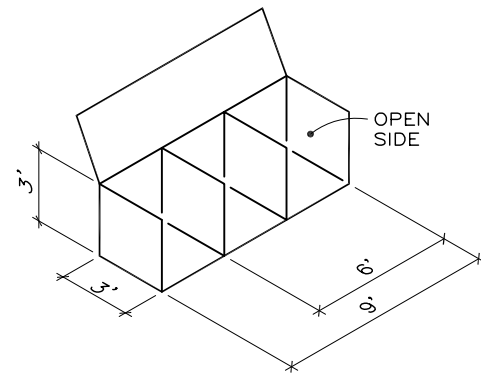

NOTE: SIZES CAN VARY
TYPICAL OPEN SIDE
NOT TO SCALE

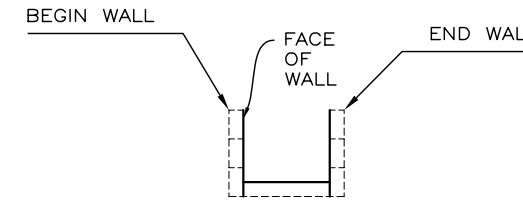

PLAN VIEW-TREE WELL
SCALE: 1"=20'

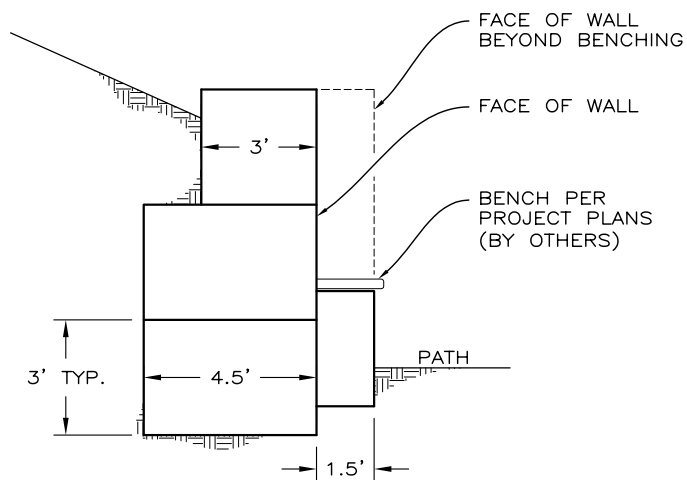

SECTION A-A
SCALE: 1"=5'

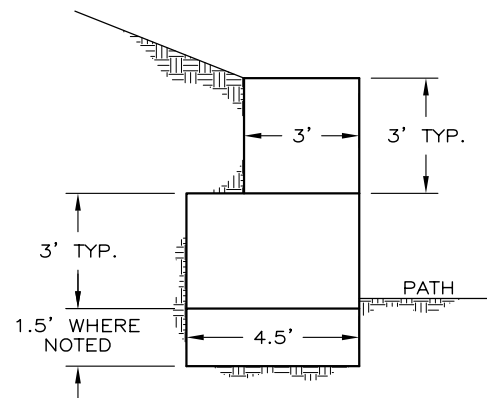

SECTION B-B
SCALE: 1"=5'

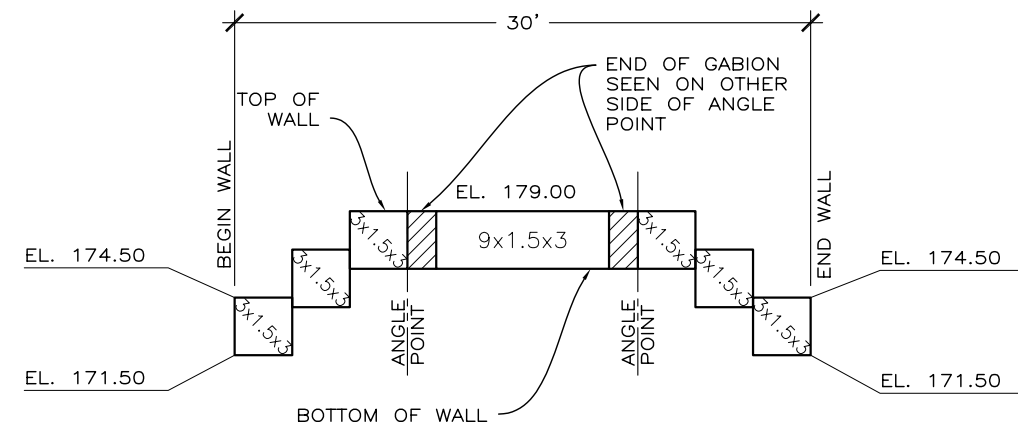

DEVELOPED ELEVATION-TREE WELL-BACK FACE
SCALE: 1"=10'

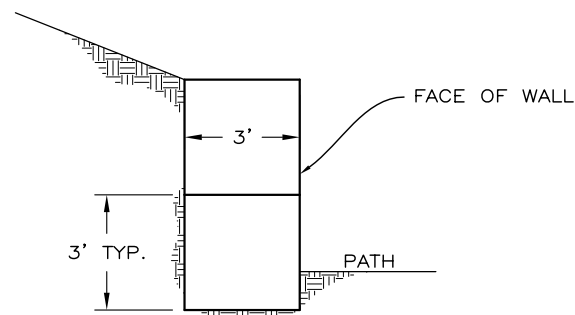

SECTION C-C
SCALE: 1"=5'

080505AG DEXTER PIT PARK DEVELOPMENT

THIS DRAWING IS FURNISHED SOLELY FOR THE USE OF OR IN CONNECTION WITH THIS PROJECT AND THE PROPRIETARY INFORMATION SHOWN HEREON IS NOT TO BE TRANSMITTED TO ANY OTHER ORGANIZATION WITHOUT SPECIFIC AUTHORIZATION BY THE HILFIKER COMPANY. HILFIKER RETAINING WALLS ARE PROTECTED BY ONE OR MORE OF THE FOLLOWING PATENTS: 243,613; 243,697; 288,616; 4,117,686; 4,329,089; 4,324,508; 4,391,557; 4,505,621; 4,343,318; 4,661,023; 4,856,939; 4,929,125; 5,076,735; 5,647,695; 5,722,799; 5,733,072; 6,357,970B1; 6,874,975B2; 7,033,118B2; AND OTHERS. OTHER PATENTS PENDING (2008)

| REV.NO. | DATE | BY | DESCRIPTION |
|---------|----------|-----|---------------------------------|
| 1 | 6 APR 10 | AMJ | RECONFIGURED GABIONS ON SHEET 5 |
| | | | |
| | | | |
| | | | |

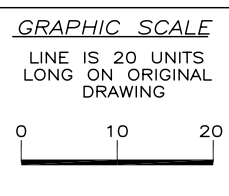

PROJ.MGR.
HKH
ENGINEER
CADD BY
AMJ

HILFIKER RETAINING WALLS

1902 Hilfiker Lane
Eureka, CA 95503-5711
TOLL-FREE 800.762.8962
PH 707.443.5093 FAX 707.443.2891
WEBSITE www.hilfiker.com E-MAIL info@hilfiker.com

DWG DATE
30 MAR 10
REVISION DATE
6 APR 10
SCALE
NOTED

SHOP DRAWING
ARTWELD GABION RETAINING WALL
DEXTER PIT PARK DEVELOPMENT
SEATTLE PARKS AND RECREATION
SEATTLE, WASHINGTON
DETAILS, SECTIONS AND TREE WELL

PROJECT NO.
080505AG
SHEET
2
OF 5

080505AG DEXTER PIT PARK DEVELOPMENT

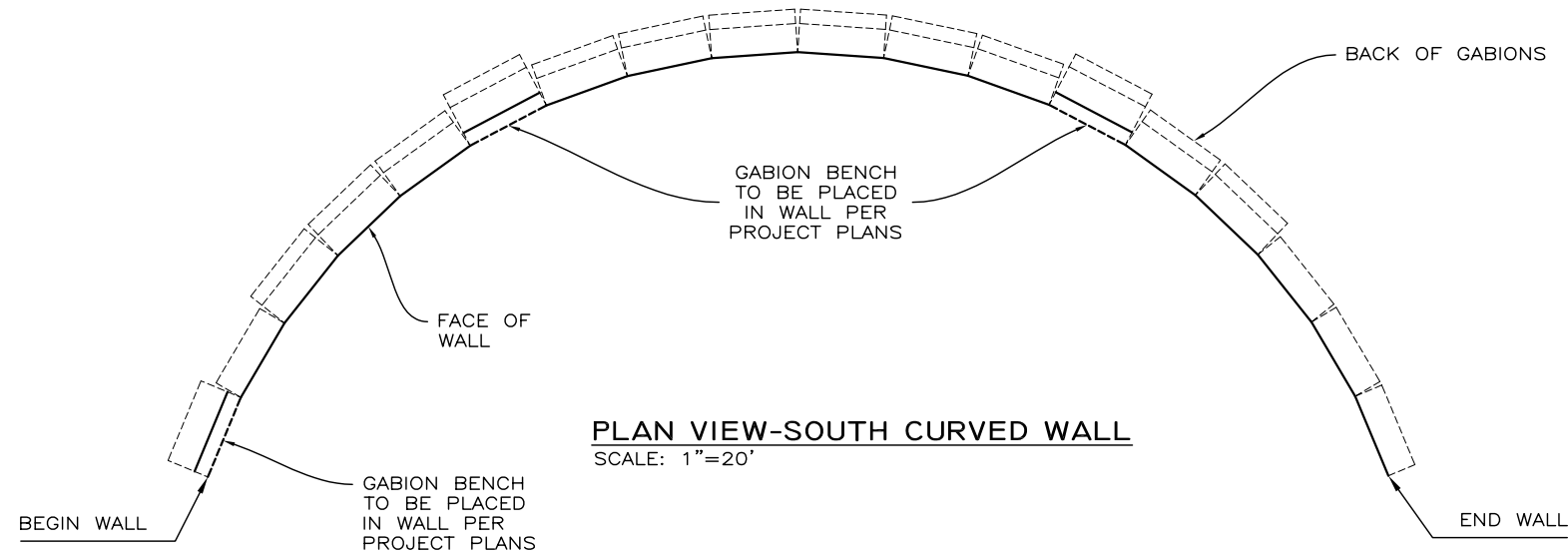

PLAN VIEW-SOUTH CURVED WALL
SCALE: 1"=20'

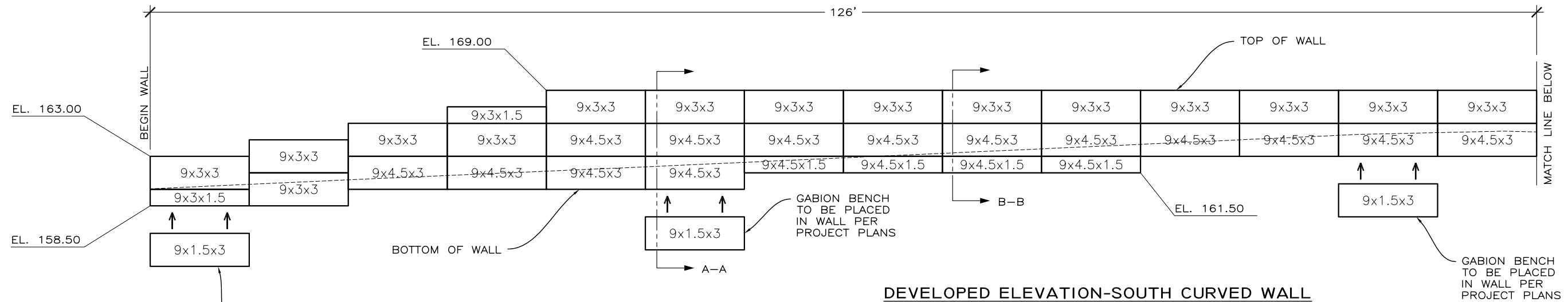

DEVELOPED ELEVATION-SOUTH CURVED WALL
SCALE: 1"=10'

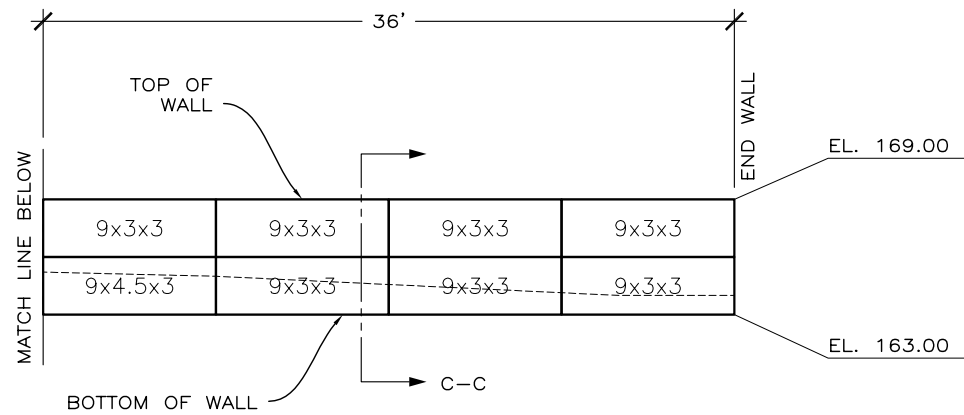

DEVELOPED ELEVATION-SOUTH CURVED WALL CONT'D
SCALE: 1"=10'

THIS DRAWING IS FURNISHED SOLELY FOR THE USE OF OR IN CONNECTION WITH THIS PROJECT AND THE PROPRIETARY INFORMATION SHOWN HEREON IS NOT TO BE TRANSMITTED TO ANY OTHER ORGANIZATION WITHOUT SPECIFIC AUTHORIZATION BY THE HILFIKER COMPANY. HILFIKER RETAINING WALLS ARE PROTECTED BY ONE OR MORE OF THE FOLLOWING PATENTS: 243,613; 243,697; 288,616; 4,117,686; 4,329,089; 4,324,508; 4,391,557; 4,505,621; 4,343,318; 4,661,023; 4,856,939; 4,929,125; 5,076,735; 5,647,695; 5,722,799; 5,733,072; 6,357,970B1; 6,874,975B2; 7,033,118B2; AND OTHERS. OTHER PATENTS PENDING (2008)

| REV. NO. | DATE | BY | DESCRIPTION |
|----------|----------|-----|---------------------------------|
| 1 | 6 APR 10 | AMJ | RECONFIGURED GABIONS ON SHEET 5 |

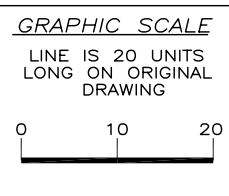

PROJ. MGR.
HKH
ENGINEER
CADD BY
AMJ

HILFIKER RETAINING WALLS

1902 Hilfiker Lane
Eureka, CA 95503-5711
TOLL-FREE 800.762.8962
PH 707.443.5093 FAX 707.443.2891
WEBSITE www.hilfiker.com E-MAIL info@hilfiker.com

DWG DATE
30 MAR 10
REVISION DATE
6 APR 10
SCALE
NOTED

SHOP DRAWING
ARTWELD GABION RETAINING WALL
DEXTER PIT PARK DEVELOPMENT
SEATTLE PARKS AND RECREATION
SEATTLE, WASHINGTON
SOUTH CURVED WALL VIEWS

PROJECT NO.
080505AG
SHEET
3
OF 5

080505AG DEXTER PIT PARK DEVELOPMENT

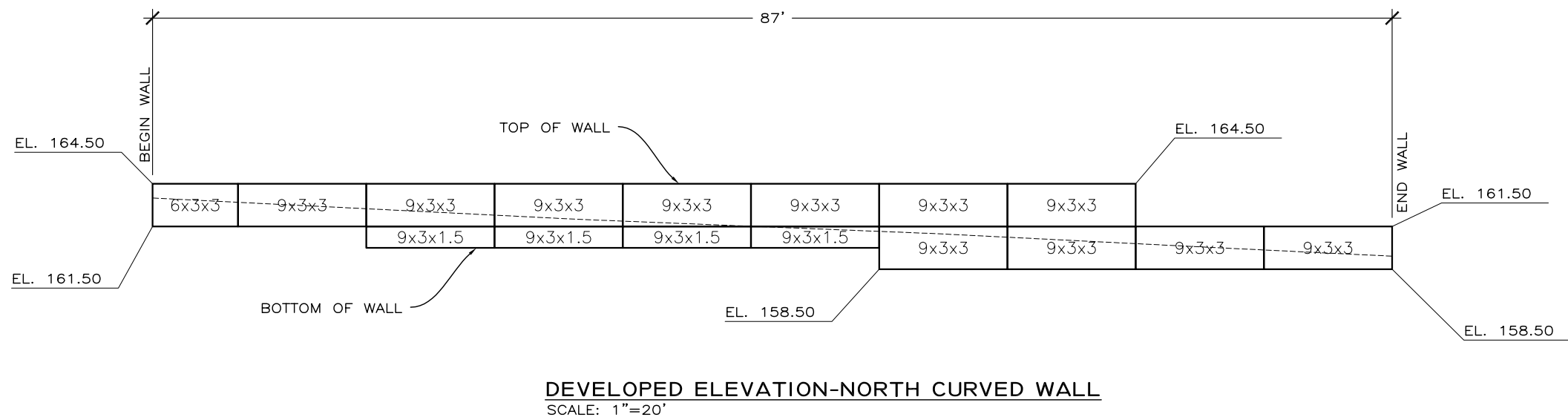
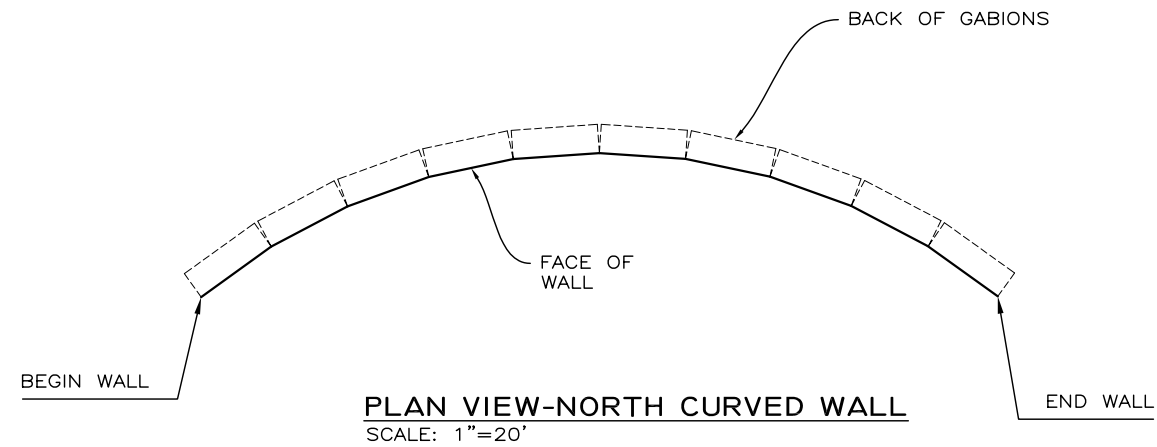

THIS DRAWING IS FURNISHED SOLELY FOR THE USE OF OR IN CONNECTION WITH THIS PROJECT AND THE PROPRIETARY INFORMATION SHOWN HEREON IS NOT TO BE TRANSMITTED TO ANY OTHER ORGANIZATION WITHOUT SPECIFIC AUTHORIZATION BY THE HILFIKER COMPANY. HILFIKER RETAINING WALLS ARE PROTECTED BY ONE OR MORE OF THE FOLLOWING PATENTS: 243,613; 243,697; 288,616; 4,117,686; 4,329,089; 4,324,508; 4,391,557; 4,505,621; 4,343,318; 4,661,023; 4,856,939; 4,929,125; 5,076,735; 5,647,695; 5,722,799; 5,733,072; 6,357,970B1; 6,874,975B2; 7,033,118B2; AND OTHERS. OTHER PATENTS PENDING (2008)

| REV.NO. | DATE | BY | DESCRIPTION |
|---------|----------|-----|---------------------------------|
| 1 | 6 APR 10 | AMJ | RECONFIGURED GABIONS ON SHEET 5 |
| | | | |
| | | | |
| | | | |
| | | | |

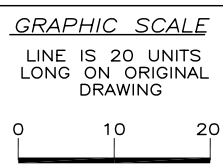

PROJ.MGR.
HKH
ENGINEER
CADD BY
AMJ

HILFIKER RETAINING WALLS

1902 Hilfiker Lane
Eureka, CA 95503-5711
TOLL-FREE 800.762.8962
PH 707.443.5093 FAX 707.443.2891
WEBSITE www.hilfiker.com E-MAIL info@hilfiker.com

DWG DATE
30 MAR 10
REVISION DATE
6 APR 10
SCALE
NOTED

SHOP DRAWING
ARTWELD GABION RETAINING WALL
DEXTER PIT PARK DEVELOPMENT
SEATTLE PARKS AND RECREATION
SEATTLE, WASHINGTON
NORTH CURVED WALL VIEWS

PROJECT NO.
080505AG
SHEET
4
OF 5

080505AG DEXTER PIT PARK DEVELOPMENT

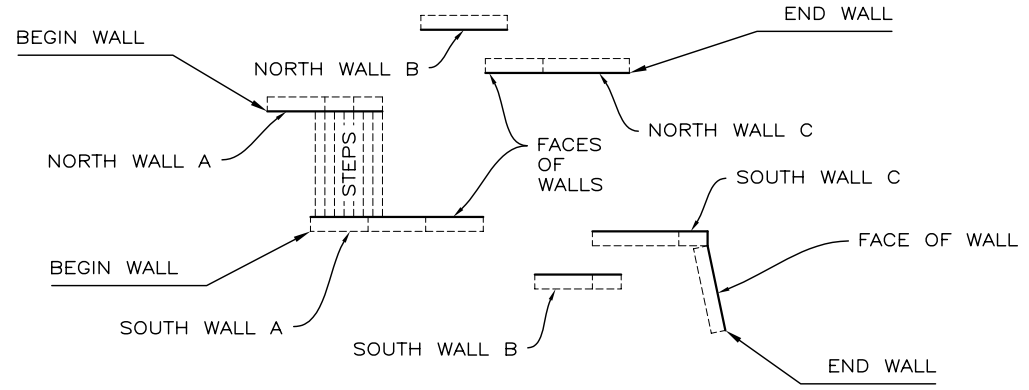

PLAN VIEW-STAIR STEP WALLS - NORTH AND SOUTH
SCALE: 1"=20'

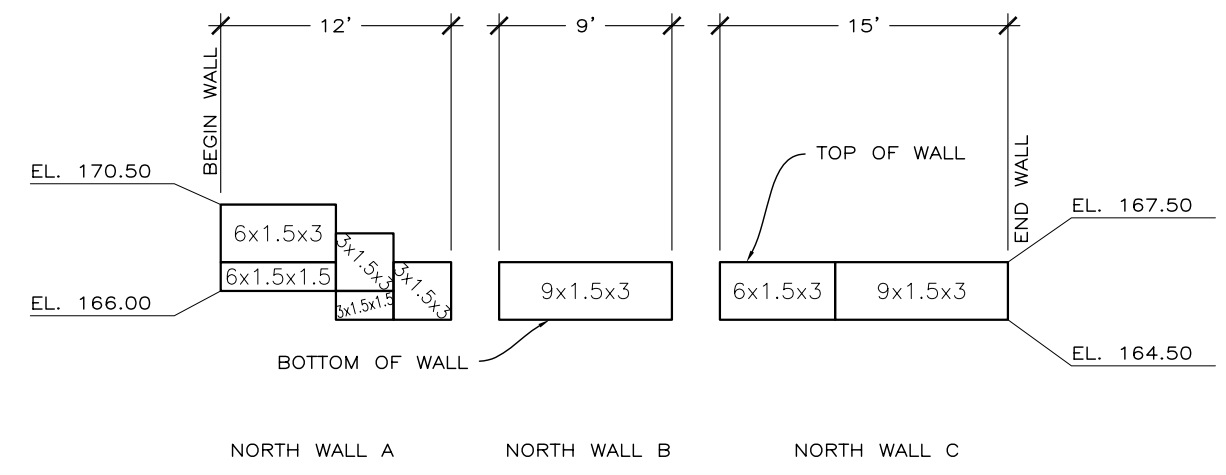

DEVELOPED ELEVATION-STAIR STEP NORTH WALL
SCALE: 1"=20'

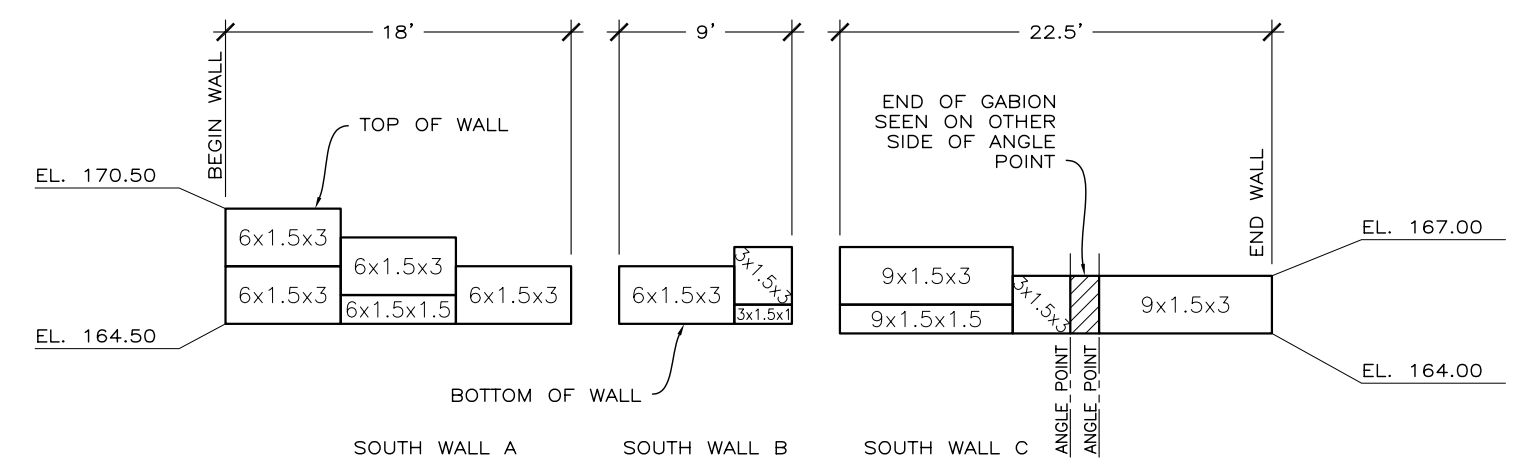

DEVELOPED ELEVATION-STAIR STEP SOUTH WALL-BACK FACE
SCALE: 1"=20'

THIS DRAWING IS FURNISHED SOLELY FOR THE USE OF OR IN CONNECTION WITH THIS PROJECT AND THE PROPRIETARY INFORMATION SHOWN HEREON IS NOT TO BE TRANSMITTED TO ANY OTHER ORGANIZATION WITHOUT SPECIFIC AUTHORIZATION BY THE HILFIKER COMPANY. HILFIKER RETAINING WALLS ARE PROTECTED BY ONE OR MORE OF THE FOLLOWING PATENTS: 243,613; 243,697; 288,616; 4,117,686; 4,329,089; 4,324,508; 4,391,557; 4,505,621; 4,343,318; 4,661,023; 4,856,939; 4,929,125; 5,076,735; 5,647,695; 5,722,799; 5,733,072; 6,357,970B1; 6,874,975B2; 7,033,118B2; AND OTHERS. OTHER PATENTS PENDING (2008)

| REV.NO. | DATE | BY | DESCRIPTION |
|---------|----------|-----|---------------------------------|
| 1 | 6 APR 10 | AMJ | RECONFIGURED GABIONS ON SHEET 5 |

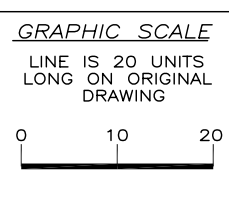

PROJ.MGR.
HKH
ENGINEER
CADD BY
AMJ

HILFIKER RETAINING WALLS

1902 Hilfiker Lane
Eureka, CA 95503-5711
TOLL-FREE 800.762.8962
PH 707.443.5093 FAX 707.443.2891
WEB SITE www.hilfiker.com E-MAIL info@hilfiker.com

DWG DATE
30 MAR 10
REVISION DATE
6 APR 10
SCALE
NOTED

SHOP DRAWING
ARTWELD GABION RETAINING WALL
DEXTER PIT PARK DEVELOPMENT
SEATTLE PARKS AND RECREATION
SEATTLE, WASHINGTON
STAIR STEP NORTH & SOUTH WALL VIEWS

PROJECT NO.
080505AG
SHEET
5
OF 5